



RADIO TEST REPORT

Applicant: Confiabits S.R.L.
Address: 28 C/Genesis UV77 MZ36
Manufacturer: Confiabits S.R.L.
Address: 28 C/Genesis UV77 MZ36
EUT: Router
Trade Mark: Confiabits
Model Number: mt7981
Date of Receipt: Dec. 09, 2023
Test Date: Dec. 09, 2023 – Jan. 03, 2024
Date of Report: Jan. 03, 2024
Prepared By: Shenzhen DL Testing Technology Co., Ltd.
Address: 101-201, Building C, Shuanghuan, No.8, Baoqing Road, Baolong Industrial Zone, Baolong Street, Longgang District, Shenzhen, Guangdong, China
Applicable Standards: ETSI EN 300 328 V2.2.2 (2019-07)
Test Result: Pass
Report Number: DL-20240102001-3E

Prepared (Engineer): Alisa Song

Reviewer (Supervisor): Jack Bu

Approved (Manager): Jade Yang



This test report is based on a single evaluation of one sample of above mentioned products. It is not permitted to be duplicated in extracts without written approval of Shenzhen DL Testing Technology Co., Ltd.



TABLE OF CONTENT

Test Report Declaration	Page
1. VERSION.....	3
2. TEST SUMMARY.....	3
3. GENERAL INFORMATION.....	4
4. TEST INSTRUMENT USED.....	12
5. RF OUTPUT POWER.....	13
6. POWER SPECTRAL DENSITY.....	25
7. ADAPTIVITY.....	34
8. OCCUPIED CHANNEL BANDWIDTH.....	45
9. TRANSMITTER UNWANTED EMISSIONS IN THE OUT-OF-BAND DOMAIN.....	48
10. TRANSMITTER UNWANTED EMISSIONS IN THE SPURIOUS DOMAIN.....	60
11. RECEIVER SPURIOUS EMISSIONS.....	64
12. RECEIVER BLOCKING.....	68
13. GEO-LOCATION CAPABILITY.....	70
14. EUT PHOTOGRAPHS.....	71

**1. VERSION**

Version No.	Date	Description
00	Jan. 03, 2024	Original

2. TEST SUMMARY

No	Test Item	Clause No	Result
Transmitter Parameters			
1	RF output power	4.3.2.2	PASS
2	Power Spectral Density	4.3.2.3	PASS
3	Duty Cycle, Tx-sequence, Tx-gap	4.3.2.4	N/A
4	Medium Utilisation (MU) factor	4.3.2.5	N/A
5	Adaptive non-FHSS using DAA	4.3.2.6	PASS
6	Occupied Channel Bandwidth	4.3.2.7	PASS
7	Transmitter unwanted emissions in the out-of-band domain	4.3.2.8	PASS
8	Transmitter unwanted emissions in the spurious domain	4.3.2.9	PASS
Receiver Parameters			
9	Receiver spurious emissions	4.3.2.10	PASS
10	Receiver Blocking	4.3.2.11	PASS
11	Geo-location capability	4.3.2.12	N/A
Note: (1) "N/A" denotes test is not applicable in this Test Report (2) Test Facility: Shenzhen DL Testing Technology Co., Ltd. Address: 101-201, Building C, Shuanghuan, No.8, Baoqing Road, Baolong Industrial Zone, Baolong Street, Longgang District, Shenzhen, Guangdong, China			



3. GENERAL INFORMATION

3.1 Description of Device (EUT)

EUT: Router

Trade Mark: Confiabits

Model Number: mt7981

Test Model: mt7981

Model difference: N/A

Power Supply: DC 12V from adapter
MODEL: SA180-120150V

Adapter: INPUT: 100-240V~ 50/60Hz 0.6A
OUTPUT: 12.0V $\overline{=}$ 1.5A 18.0W

Operation Frequency: 802.11b/g/n20:2412~2472 MHz
802.11n40:2422~2462 MHz

Modulation Type: CCK/OFDM/DBPSK/DAPSK

Number of Channel: 802.11b/g/n20:13CH
802.11n40:11 CH
802.11b:11/5.5/2/1 Mbps

Data Rate: 802.11g:54/48/36/24/18/12/9/6Mbps
802.11n Up to 150Mbps

Antenna Type: External Antenna*2

Antenna Gain: 5 dBi

Receiver Category: 1

Hardware Version: 1.0

Software Version: 1.0

Firmware: ---

Note1: For a more detailed features description, please refer to the manufacturer's specifications or the User's Manual.

Note2: The EUT's all information provided by client.

Channel List for 802.11b/g/n HT20							
Channel	Frequency (MHz)	Channel	Frequency (MHz)	Channel	Frequency (MHz)	Channel	Frequency (MHz)
01	2412	05	2432	09	2452	13	2472
02	2417	06	2437	10	2457	/	/
03	2422	07	2442	11	2462	/	/
04	2427	08	2447	12	2467	/	/

Channel List for 802.11 n HT40							
Channel	Frequency (MHz)	Channel	Frequency (MHz)	Channel	Frequency (MHz)	Channel	Frequency (MHz)
03	2422	06	2437	09	2452	/	/
04	2427	07	2442	10	2457	/	/
05	2432	08	2447	11	2462	/	/

**ANNEX E.2****a) The type of wideband data transmission equipment:**

- FHSS
- non-FHSS

b) In case of FHSS:

- In case of non-Adaptive FHSS equipment:
The number of Hopping Frequencies:
- In case of Adaptive FHSS equipment:
The maximum number of Hopping Frequencies:
The minimum number of Hopping Frequencies:
- The (average) dwell time:

c) Adaptive / non-adaptive equipment:

- non-adaptive Equipment
- adaptive Equipment without the possibility to switch to a non-adaptive mode
- adaptive Equipment which can also operate in a non-adaptive mode

d) In case of adaptive equipment:

- The Channel Occupancy Time implemented by the equipment: ms
- The equipment has implemented an LBT mechanism
- In case of non-FHSS equipment:
 - The equipment is Frame Based equipment
 - The equipment is Load Based equipment
 - The equipment can switch dynamically between Frame Based and Load Based equipment
- The CCA time implemented by the equipment: μ s
- The equipment has implemented a DAA mechanism
- The equipment can operate in more than one adaptive mode

e) In case of non-adaptive Equipment:

- The maximum RF Output Power (e.i.r.p.): 15.91 dBm
- The maximum (corresponding) Duty Cycle: %
- Equipment with dynamic behaviour, that behaviour is described here. (e.g. the different combinations of duty cycle and corresponding power levels to be declared):

f) The worst case operational mode for each of the following tests:

- RF Output Power
802.11b
- Power Spectral Density
802.11b
- Duty cycle, Tx-Sequence, Tx-gap
802.11b
- Accumulated Transmit time, Frequency Occupation & Hopping Sequence (only for FHSS equipment)



- Hopping Frequency Separation (only for FHSS equipment)
- Medium Utilisation
- Adaptivity & Receiver Blocking
- Nominal Channel Bandwidth
20/40MHz
- Transmitter unwanted emissions in the OOB domain
802.11b
- Transmitter unwanted emissions in the spurious domain
802.11b
- Receiver spurious emissions
802.11b

g) The different transmit operating modes (tick all that apply):

- Operating mode 1: Single Antenna Equipment
 - Equipment with only one antenna
 - Equipment with two diversity antennas but only one antenna active at any moment in time
 - Smart Antenna Systems with two or more antennas, but operating in a (legacy) mode where only one antenna is used (e.g. IEEE 802.11™ legacy mode in smart antenna systems)
- Operating mode 2: Smart Antenna Systems - Multiple Antennas without beam forming
 - Single spatial stream/Standard throughput/(e.g. IEEE 802.11™ legacy mode)
 - High Throughput (> 1 spatial stream) using Nominal Channel Bandwidth 1
 - High Throughput (> 1 spatial stream) using Nominal Channel Bandwidth 2

NOTE1: Add more lines if more channel bandwidths are supported.

- Operating mode 3: Smart Antenna Systems - Multiple Antennas with beam forming
 - Single spatial stream/Standard throughput (e.g. IEEE 802.11™ legacy mode)
 - High Throughput (> 1 spatial stream) using Nominal Channel Bandwidth 1
 - High Throughput (> 1 spatial stream) using Nominal Channel Bandwidth 2

NOTE2: Add more lines if more channel bandwidths are supported.

h) In case of Smart Antenna Systems:

- The number of Receive chains:
- The number of Transmit chains:
- symmetrical power distribution
- asymmetrical power distribution

In case of beam forming, the maximum (additional) beam forming gain: dB

NOTE: The additional beam forming gain does not include the basic gain of a single antenna.



i) Operating Frequency Range(s) of the equipment:

- Operating Frequency Range 1: 2412 MHz to 2472 MHz
- Operating Frequency Range 2: 2422 MHz to 2462 MHz

NOTE: Add more lines if more Frequency Ranges are supported.

j) Occupied Channel Bandwidth(s):

- Nominal Channel Bandwidth 1: 16.591MHz
- Nominal Channel Bandwidth 2: 37.633 MHz

NOTE: Add more lines if more channel bandwidths are supported.

k) Type of Equipment (stand-alone, combined, plug-in radio device, etc.):

- Stand-alone
- Combined Equipment
- Plug-in radio device
- Other

l) The normal and the extreme operating conditions that apply to the equipment:

Normal operating conditions (if applicable):

Operating temperature: 25° C

Other (please specify if applicable):

Extreme operating conditions:

Operating temperature range: Minimum: -20 °C Maximum 55°C

Other (please specify if applicable): Minimum: Maximum

Details provided are for the: stand-alone equipment

- combined (or host) equipment
- test jig

m) The intended combination(s) of the radio equipment power settings and one or more antenna assemblies and their corresponding e.i.r.p. levels:

- Antenna Type

External Antenna (information to be provided in case of conducted measurements)

Antenna Gain: 5 dBi

If applicable, additional beamforming gain (excluding basic antenna gain): dB

- Temporary RF connector provided
- No temporary RF connector provided
- Dedicated Antennas (equipment with antenna connector)
- Single power level with corresponding antenna(s)
- Multiple power settings and corresponding antenna(s)

Number of different Power Levels:

Power Level 1: dBm

Power Level 2: dBm

Power Level 3: dBm

NOTE 1: Add more lines in case the equipment has more power levels.



NOTE 2: These power levels are conducted power levels (at antenna connector).

- For each of the Power Levels, provide the intended antenna assemblies, their corresponding gains (G) and the resulting e.i.r.p. levels also taking into account the beamforming gain (Y) if applicable

Power Level 1: dBm

Number of antenna assemblies provided for this power level:

Assembly #	Gain (dBi)	e.i.r.p. (dBm)	Part number or model name
1	5	15.63	
2	5	15.91	
3			
4			

NOTE 3: Add more rows in case more antenna assemblies are supported for this power level.

Power Level 2: dBm

Number of antenna assemblies provided for this power level:

Assembly #	Gain (dBi)	e.i.r.p. (dBm)	Part number or model name
1			
2			
3			
4			

NOTE 4: Add more rows in case more antenna assemblies are supported for this power level.

Power Level 3: dBm

Number of antenna assemblies provided for this power level:

Assembly #	Gain (dBi)	e.i.r.p. (dBm)	Part number or model name
1			
2			
3			
4			

NOTE 5: Add more rows in case more antenna assemblies are supported for this power level.

n) The nominal voltages of the stand-alone radio equipment or the nominal voltages of the combined equipment or test jig in case of plug-in devices:

- Details provided are for the:
- stand-alone equipment
 - combined equipment
 - test jig

Supply Voltage AC mains State AC voltage 230V
 DC State DC voltage : V

In case of DC, indicate the type of power source

- Internal Power Supply



- External Power Supply or AC/DC adapter
- Battery: V
- Other:

o) Describe the test modes available which can facilitate testing:

The EUT can be into the Engineer mode for testing.

p) The equipment type (e.g. Bluetooth®, IEEE 802.11™, IEEE 802.15.4™, proprietary, etc.):

IEEE 802.11™

q) If applicable, the statistical analysis referred to in clause 5.4.1 q)

(to be provided as separate attachment)

r) If applicable, the statistical analysis referred to in clause 5.4.1 r)

(to be provided as separate attachment)

s) Geo-location capability supported by the equipment:

- Yes
- The geographical location determined by the equipment as defined in clause 4.3.1.13.2 or clause 4.3.2.12.2 is not accessible to the user
- No

ANNEX E.3

From all combinations of conducted power settings and intended antenna assembly(ies) specified in clause 5.4.1 m), specify the combination resulting in the highest e.i.r.p. for the radio equipment.

Unless otherwise specified in ETSI EN 300 328, this power setting is to be used for testing against the requirements of ETSI EN 300 328. In case there is more than one such conducted power setting resulting in the same (highest) e.i.r.p. level, the highest power setting is to be used for testing. See also ETSI EN 300 328, clause 5.3.2.3.

Highest overall e.i.r.p. value: dBm	
Corresponding Antenna assembly gain: dBi	Antenna Assembly #:
Corresponding conducted power setting: dBm (also the power level to be used for testing)	Listed as Power Setting #:

ANNEX E.4.1

ITU Class(es) of emission:

Can the transmitter operate unmodulated? yes no

ANNEX E.4.2

- The transmitter is intended for:
- Continuous duty
 - Intermittent duty
 - Continuous operation possible for testing purposes

ANNEX E.4.3

- The equipment submitted are representative production models
- If not, the equipment submitted are pre-production models?



- If pre-production equipment are submitted, the final production equipment will be identical in all respects with the equipment tested
- If not, supply full details

ANNEX E.4.4

- Spare batteries (e.g. for portable equipment)
- Battery charging device
- External Power Supply or AC/DC adapter
- Test jig or interface box
- RF test fixture (for equipment with integrated antennas)
- Combined equipment Manufacturer:
- Model #:
- Model name:
- User Manual
- Technical documentation (Handbook and circuit diagrams)

3.2 Tested System Details

None.

3.3 Block Diagram of Test Set-up



3.4 Test Mode Description

Mode	data rate (Mbps)	Channel	Frequency (MHz)
802.11b	11	Low: CH1	2412
	11	Middle: CH7	2442
	11	High: CH13	2472
802.11g	54	Low: CH1	2412
	54	Middle: CH7	2442
	54	High: CH13	2472
802.11n HT20	MCS1	Low: CH1	2412
	MCS1	Middle: CH7	2442
	MCS1	High: CH13	2472
802.11n HT40	MCS1	Low: CH1	2422
	MCS1	Middle: CH7	2442
	MCS1	High: CH11	2462



3.5 Test Conditions

	Normal Conditions	Extreme Conditions	
Temperature range	25°C	HTHV	AC 253V, 55°C
		HTLV	AC 207V, 55°C
Power supply	AC 230V	LTLV	AC 207V, -20°C
		LTHV	AC 253V, -20°C

Note 1: The test procedure described in clause 5.1 of EN300 328 was used for extreme test procedure.
2: The Extreme Temperature and Extreme Voltages declared by the manufacturer.

3.6 Test Uncertainty

Item	MU	Remark
Uncertainty for Conducted Emission Test	2.50dB	
Uncertainty for Radiation Emission test in 3m chamber (30MHz to 1GHz)	3.04dB	Polarize: V
	3.02dB	Polarize: H
Uncertainty for Radiation Emission test in 3m chamber (Above)	3.56dB	Polarize: H
	3.84dB	Polarize: V
Uncertainty for radio frequency	1×10^{-9}	
Uncertainty for conducted RF Power	0.65dB	
Uncertainty for temperature	0.6°C	
Uncertainty for humidity	1%	



4. TEST INSTRUMENT USED

Equipment	Manufacturer	Model	Serial	Last Cal.	Next Cal.
Comprehensive Tester	ROHDE&SCHWARZ	CMW500	106504	Nov. 04, 2023	Nov. 03, 2024
Spectrum Analyzer	KEYSIGHT	N9020A	MY55370280	Nov. 04, 2023	Nov. 03, 2024
Signal Source	Agilent	N5182A	MY46240766	Nov. 04, 2023	Nov. 03, 2024
Signal Source	Agilent	83752B	3610A01631	Nov. 04, 2023	Nov. 03, 2024
Probe	KEYSIGHT	U2021XA	MY55210018	Nov. 04, 2023	Nov. 03, 2024
Attenuator	MAIWEI	MANASR0206 S2	DLE-160	Nov. 04, 2023	Nov. 03, 2024
RF Control Box	MAIWEI	MW100-RFCB	DLE-179	Nov. 04, 2023	Nov. 03, 2024
RF Control Box	MAIWEI	MW200-RFCB	DLE-180	Nov. 04, 2023	Nov. 03, 2024
RF Cable	MAIWEI	Z302S	18054391	Nov. 04, 2023	Nov. 03, 2024
RF Cable	MAIWEI	Z302S	19051973	Nov. 04, 2023	Nov. 03, 2024
RF Cable	MAIWEI	Z302S	19051987	Nov. 04, 2023	Nov. 03, 2024
RF Cable	MAIWEI	Z302S	19051988	Nov. 04, 2023	Nov. 03, 2024
RF Cable	MAIWEI	Z302S	19063251	Nov. 04, 2023	Nov. 03, 2024
RF Cable	MAIWEI	Z302S	19063254	Nov. 04, 2023	Nov. 03, 2024
RF Cable	MAIWEI	Z302S	19063257	Nov. 04, 2023	Nov. 03, 2024
RF Cable	MAIWEI	Z302S	19063259	Nov. 04, 2023	Nov. 03, 2024
DC power	LODESTAR	LP532DE	LP1908158	Nov. 04, 2023	Nov. 03, 2024
966 chamber	ChengYu	966 Room	966	Nov. 06, 2023	Nov. 05, 2026
Spectrum Analyzer	Agilent	E4408B	MY50140780	Nov. 04, 2023	Nov. 03, 2024
EMI Receiver	R&S	ESRP7	101393	Nov. 04, 2023	Nov. 03, 2024
Amplifier	Schwarzbeck	BBV9743B	00153	Nov. 04, 2023	Nov. 03, 2024
Amplifier	EMEC	EM01G8GA	00270	Nov. 04, 2023	Nov. 03, 2024
Active Loop Antenna	Daze	ZN30900A	SEL0097	Nov. 04, 2023	Nov. 03, 2024
Broadband Trilog Antenna	Schwarzbeck	VULB9162	00306	Nov. 04, 2023	Nov. 03, 2024
Horn Antenna	Schwarzbeck	BBHA9120D	02139	Nov. 04, 2023	Nov. 03, 2024
966 Cable 1#	ChengYu	966	004	Nov. 04, 2023	Nov. 03, 2024
966 Cable 2#	ChengYu	966	003	Nov. 04, 2023	Nov. 03, 2024
Temperature Controller	Terchy	MHQ	120	Nov. 04, 2023	Nov. 03, 2024

5. RF OUTPUT POWER

5.1 Block Diagram of Test Setup

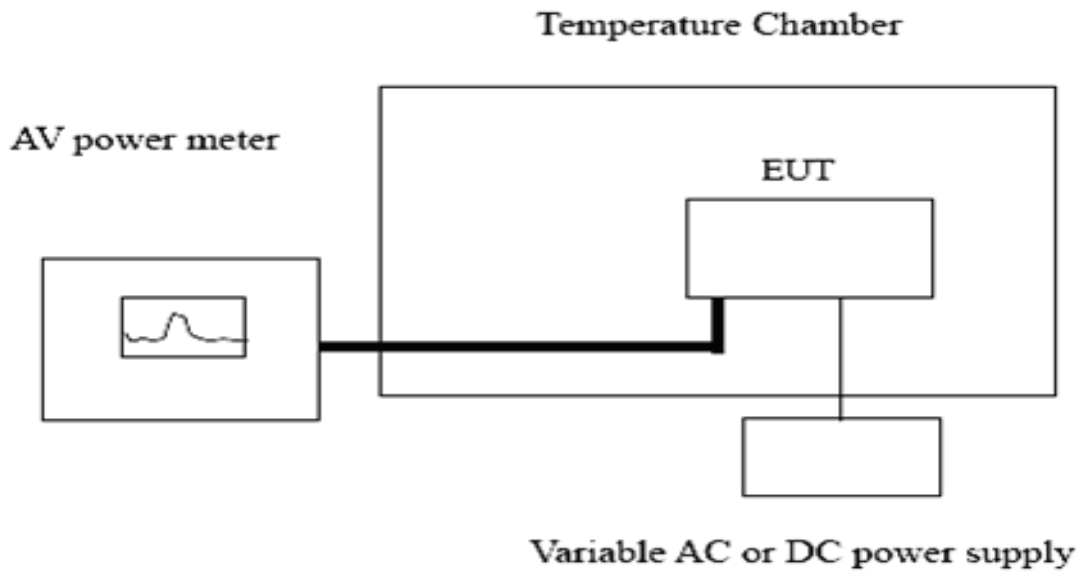

5.2 Limit

The RF output power for non-FHSS equipment shall be equal to or less than 20 dBm.

Notes: For Non-adaptive FHSS equipment, the manufacturer may have declared a reduced RF Output Power (see clause 5.4.1 m)) and associated Duty Cycle (see clause 5.4.1 e)) that will ensure that the equipment meets the requirement for the Medium Utilization (MU) factor further described in clause 4.3.2.5.

This is verified by the conformance test referred to in clause 4.3.2.5.4.

For non-adaptive non-FHSS equipment, where the manufacturer has declared an RF output power of less than 20 dBm e.i.r.p., the RF output power shall be equal to or less than that declared value.

5.3 Test Procedure

Refer to ETSI EN 300 328 V2.2.2 Clause 5.4.2.2.1.1



5.4 Test Result

Antenna 1 Total e.i.r.p (dBm) Result								
Mode	Test CH	Condition					Limit (dBm)	Result
		Normal	HTLV	LTLV	LTHV	HTHV		
802.11b	Low	15.63	15.34	15.45	15.62	15.60	20.00	Pass
	Middle	15.38	15.10	15.20	15.42	15.35	20.00	Pass
	High	15.30	15.02	15.12	15.34	15.27	20.00	Pass
802.11g	Low	14.08	13.82	13.91	14.12	14.05	20.00	Pass
	Middle	13.90	13.65	13.74	13.93	13.87	20.00	Pass
	High	13.74	13.49	13.58	13.77	13.72	20.00	Pass
802.11n HT20	Low	14.22	13.96	14.05	14.26	14.19	20.00	Pass
	Middle	13.87	13.62	13.71	13.90	13.85	20.00	Pass
	High	13.79	13.54	13.63	13.82	13.77	20.00	Pass
802.11n HT40	Low	12.61	12.38	12.46	12.64	12.59	20.00	Pass
	Middle	12.31	12.08	12.16	12.34	12.29	20.00	Pass
	High	11.89	15.34	15.45	15.62	15.60	20.00	Pass



Antenna 2 Total e.i.r.p (dBm) Result								
Mode	Test CH	Condition					Limit (dBm)	Result
		Normal	HTLV	LTLV	LTHV	HTHV		
802.11b	Low	15.91	15.62	15.72	15.90	15.88	20.00	Pass
	Middle	15.86	15.57	15.67	15.90	15.83	20.00	Pass
	High	15.63	15.34	15.45	15.67	15.60	20.00	Pass
802.11g	Low	14.55	14.39	14.49	14.70	14.63	20.00	Pass
	Middle	14.41	14.19	14.28	14.49	14.42	20.00	Pass
	High	14.58	14.37	14.47	14.68	14.61	20.00	Pass
802.11n HT20	Low	13.10	12.86	12.95	13.13	13.08	20.00	Pass
	Middle	12.95	12.71	12.80	12.98	12.93	20.00	Pass
	High	12.68	12.45	12.53	12.71	12.66	20.00	Pass
802.11n HT40	Low	12.55	12.32	12.40	12.58	12.53	20.00	Pass
	Middle	12.69	12.46	12.54	12.72	12.67	20.00	Pass
	High	12.56	12.33	12.41	12.59	12.54	20.00	Pass



MIMO Total e.i.r.p (dBm) Result					
Mode	Test CH	Antenna	Total Output Power(dB)	Limit (dBm)	Result
			Normal		
802.11n HT20	Low	Antenna1+ Antenna2	16.71	20.00	Pass
	Middle		16.44	20.00	Pass
	High		16.28	20.00	Pass
802.11n HT40	Low		15.59	20.00	Pass
	Middle		15.51	20.00	Pass
	High		15.25	20.00	Pass



Antenna 1 802.11b Normal:

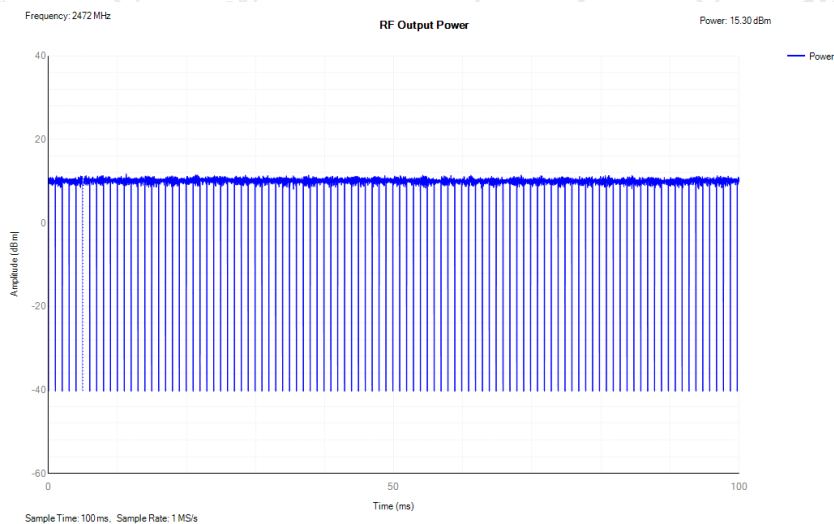
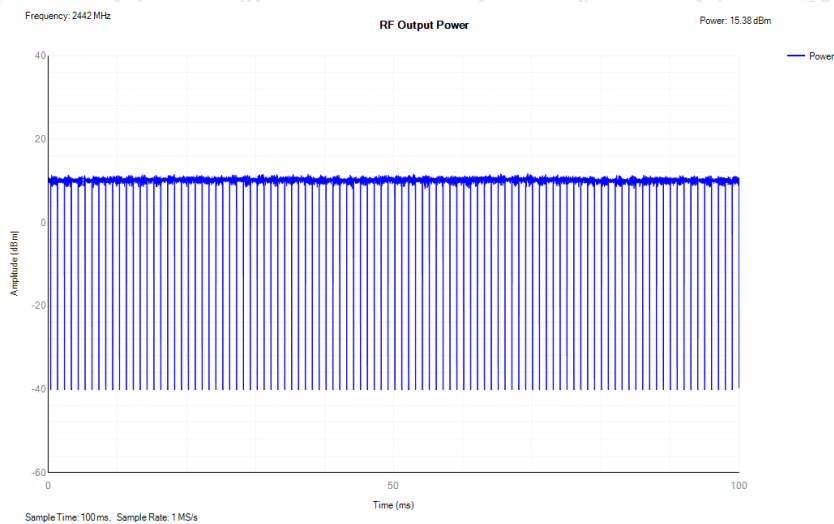
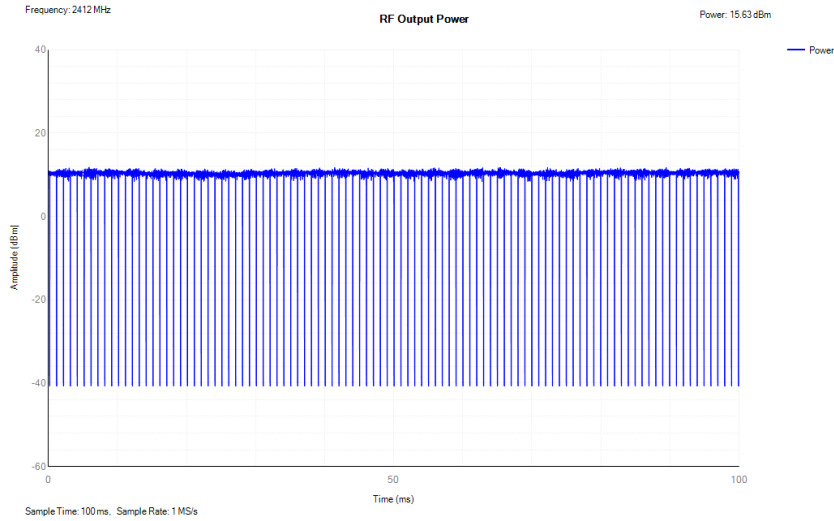



802.11g Normal:

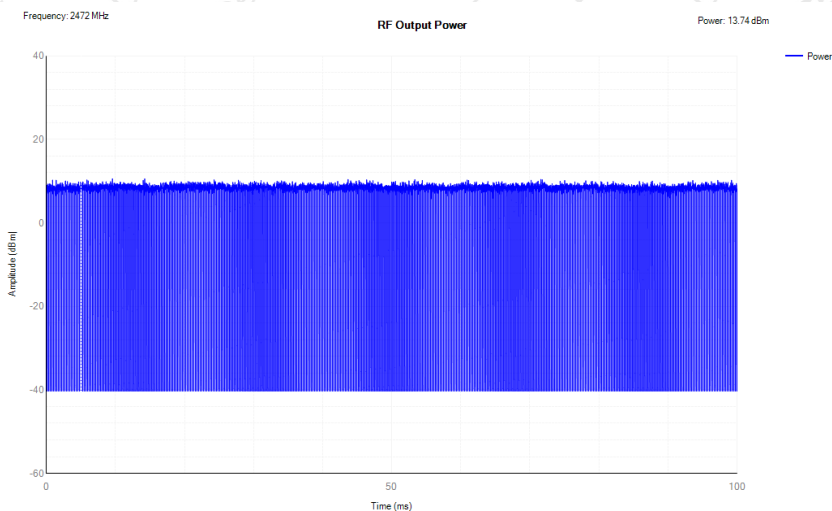
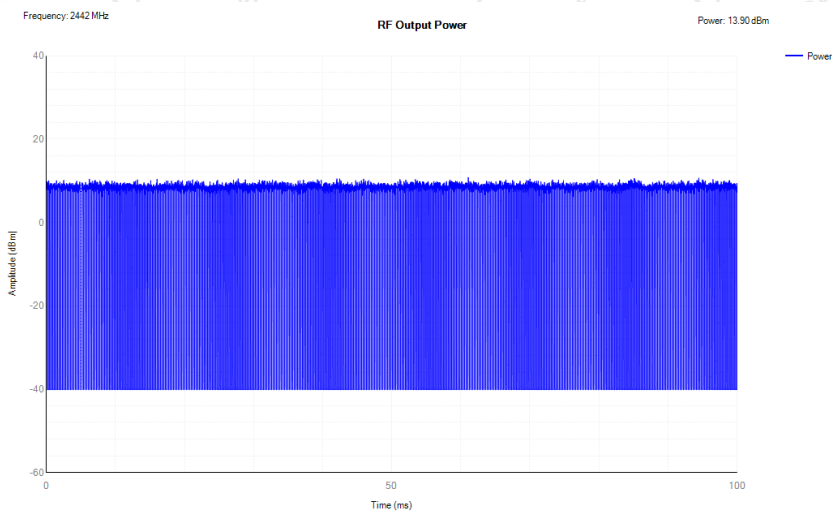
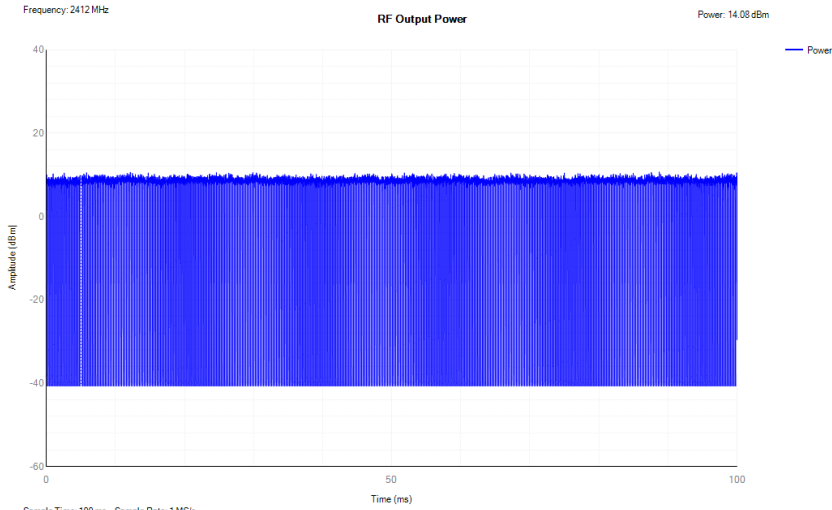



802.11n HT20 Normal:

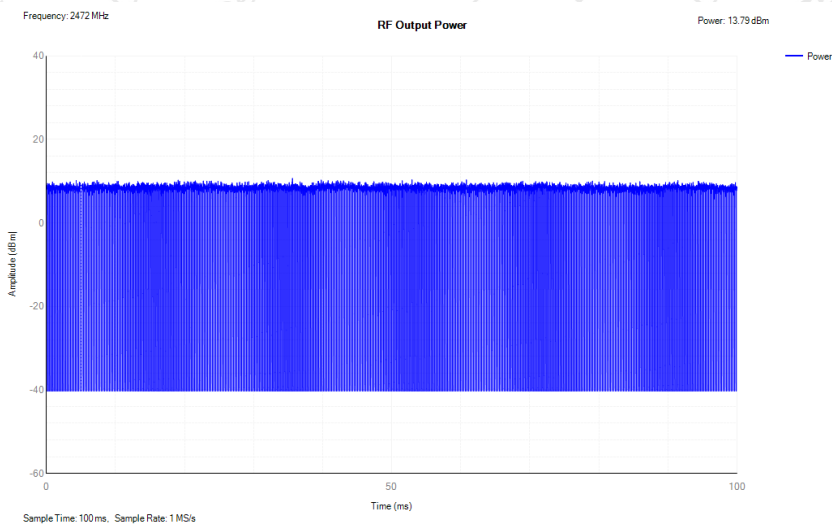
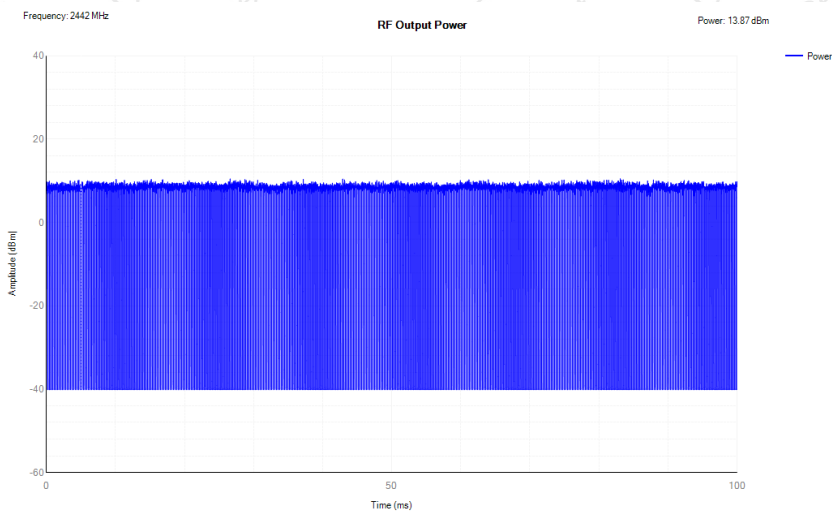
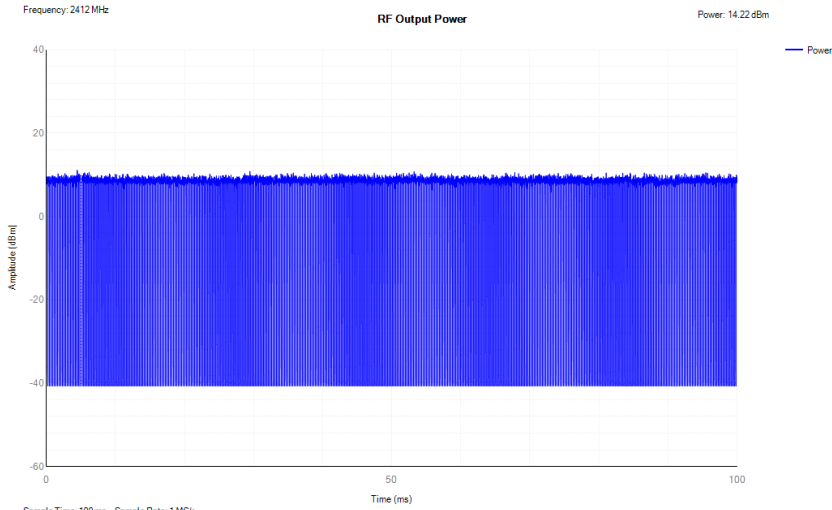



802.11n HT40 Normal:

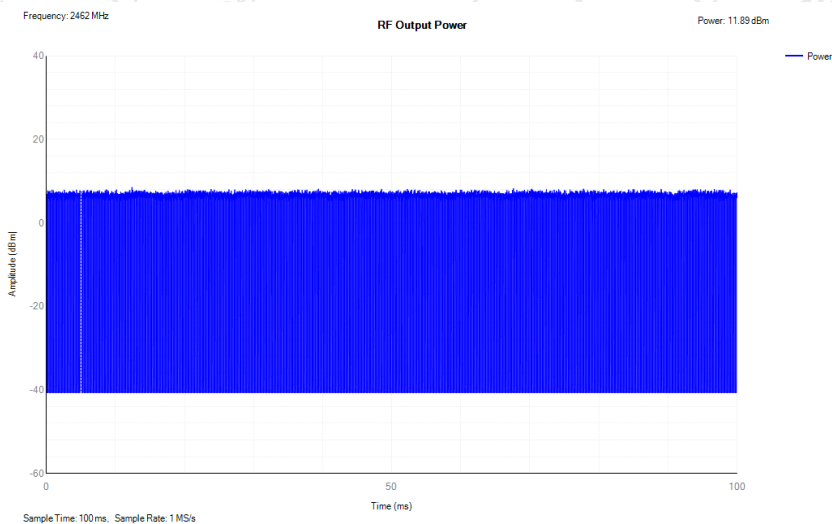
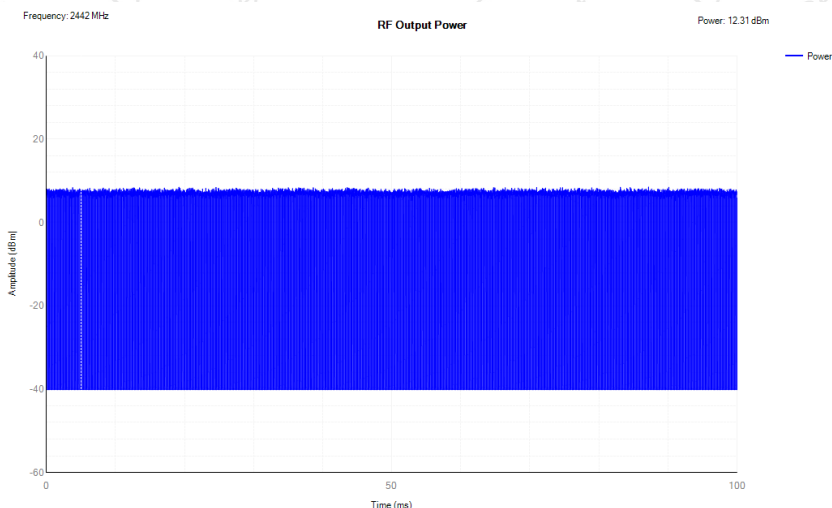
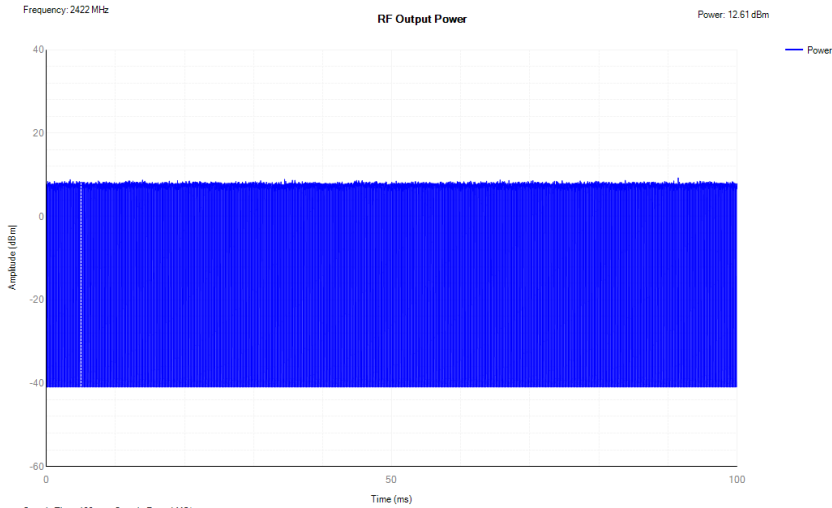



Antenna 2 802.11b Normal:

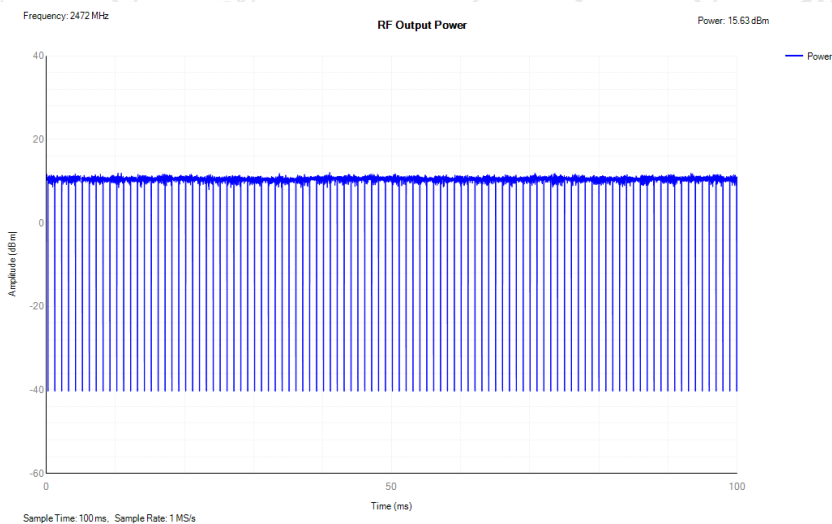
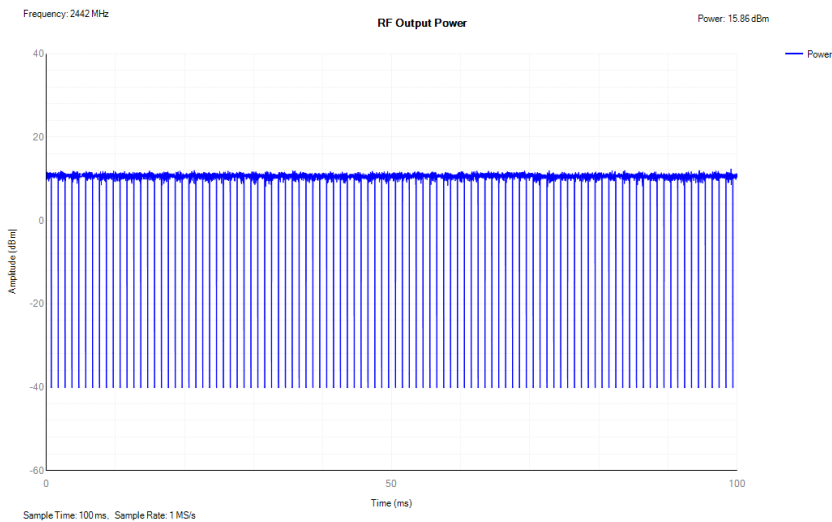
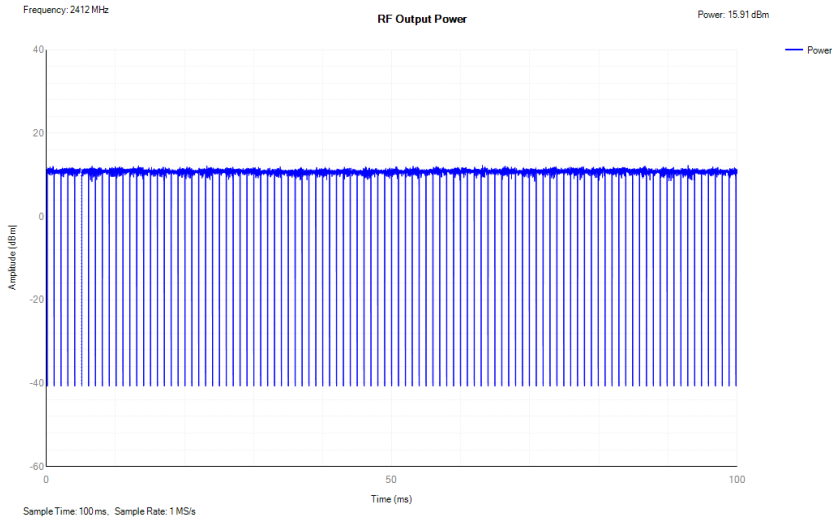



802.11g Normal:

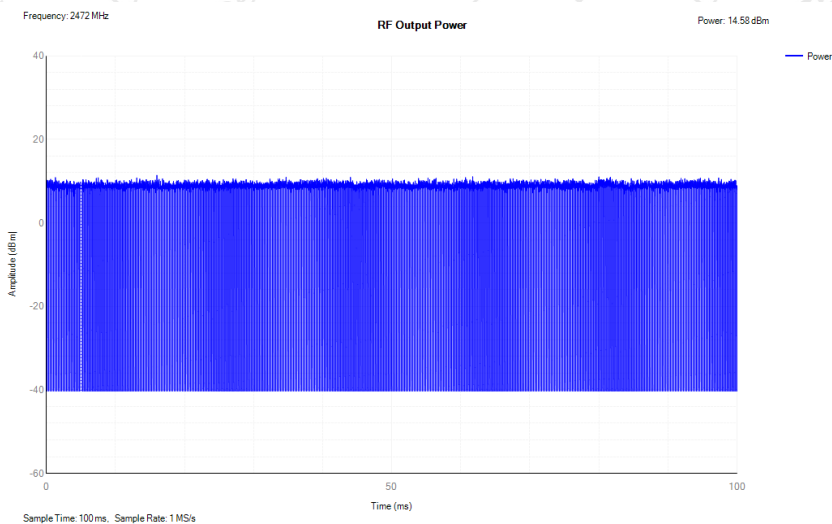
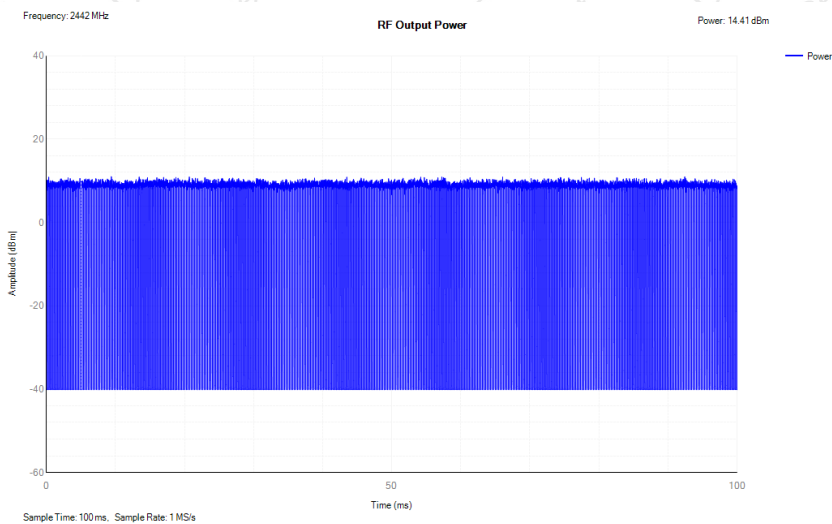
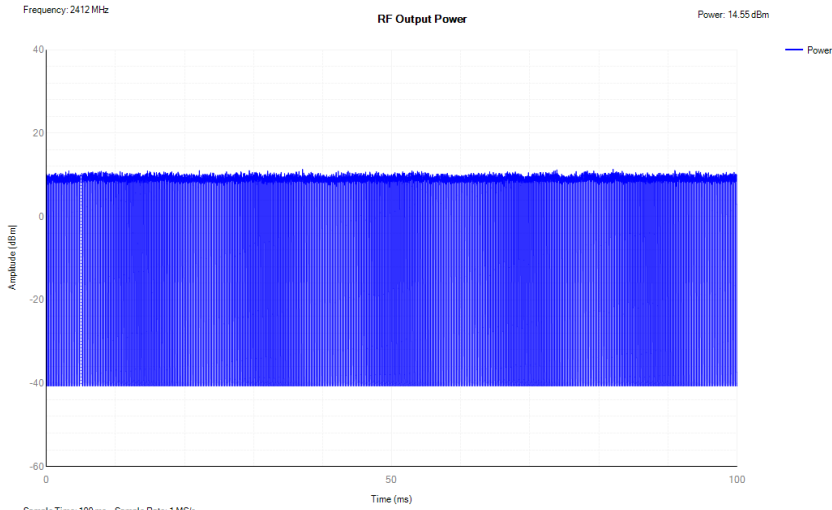



802.11n HT20 Normal:

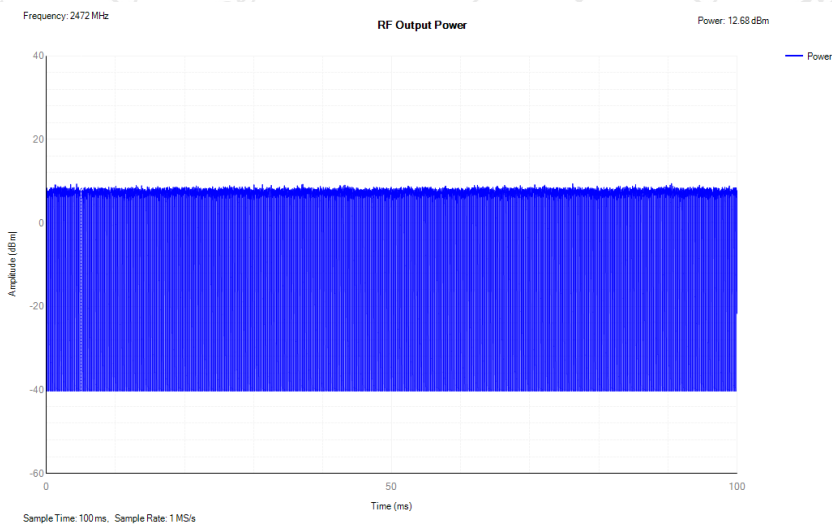
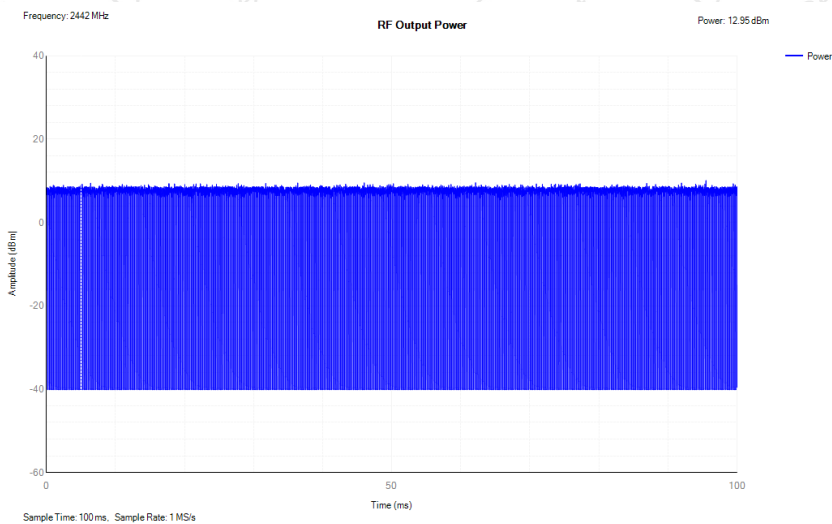
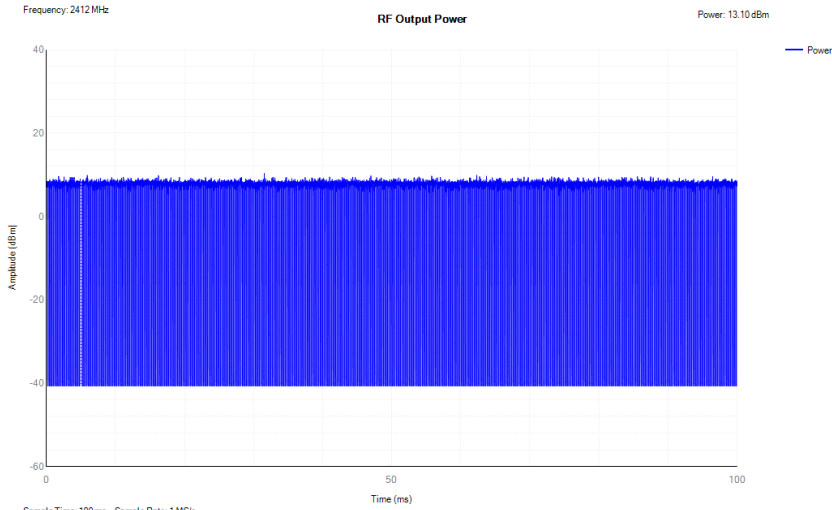



802.11n HT40 Normal:

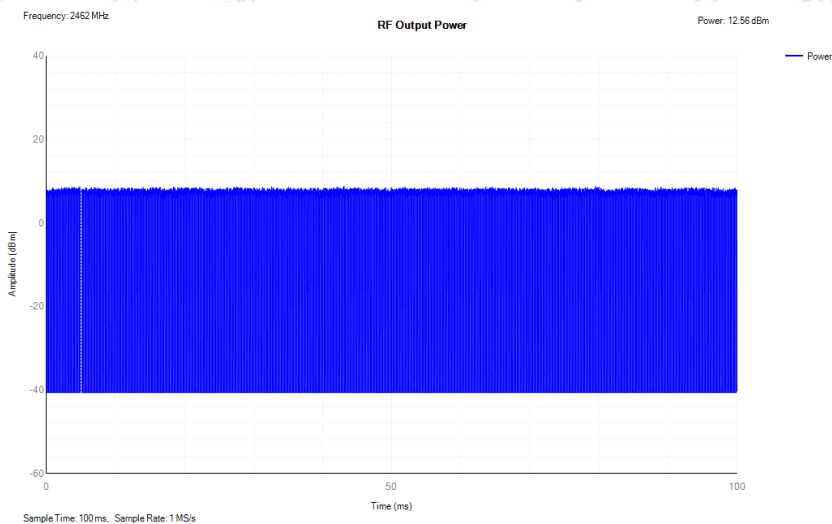
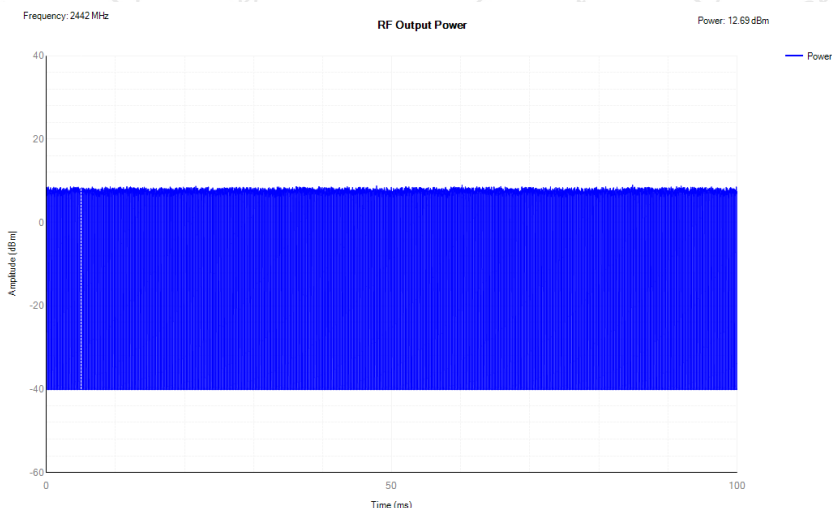
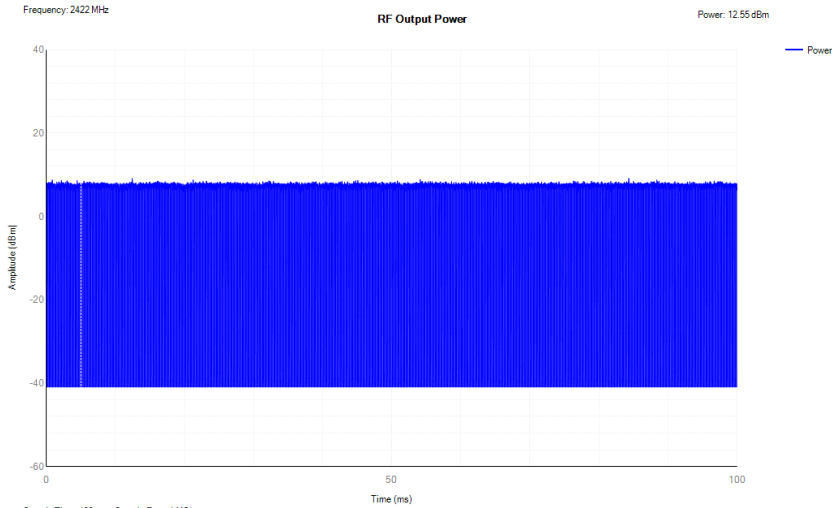



6. POWER SPECTRAL DENSITY

6.1 Block Diagram of Test Setup

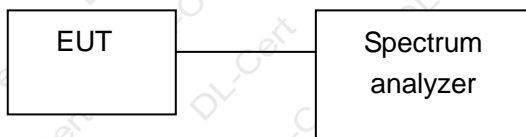

6.2 Test Standard and Limit

The maximum Power Spectral Density for non-FHSS equipment is 10 dBm per MHz.

6.3 Test Procedure

Refer to ETSI EN 300 328 V2.2.2 Clause 5.4.3

Connect the UUT to the spectrum analyzer and use the following settings:

Start Frequency	2400 MHz
Stop Frequency	2483.5 MHz
RBW	10KHz
VBW	30KHz
Detector	RMS
Sweep points	>8350
Trace	Max Hold
Trigger	Free Run

6.4 Test Result

Mode	Channel	Antenna1 Power Spectral Density (dBm/MHz)	Antenna2 Power Spectral Density (dBm/MHz)	MIMO Power Spectral Density (dBm/MHz)	Limit (dBm/MHz)	Conclusion
802.11b	Low	4.69	4.97	/	10.00	PASS
	Middle	4.59	5.18	/	10.00	PASS
	High	4.34	4.61	/	10.00	PASS
802.11g	Low	3.17	3.65	/	10.00	PASS
	Middle	3.12	3.95	/	10.00	PASS
	High	2.92	3.72	/	10.00	PASS
802.11n HT20	Low	3.17	1.74	5.52	10.00	PASS
	Middle	3.19	1.72	5.53	10.00	PASS
	High	3.10	1.34	5.32	10.00	PASS
802.11n HT40	Low	-1.29	-1.34	1.70	10.00	PASS
	Middle	-1.42	-0.96	1.83	10.00	PASS
	High	-1.86	-1.25	1.47	10.00	PASS



Antenna 1

802.11b :

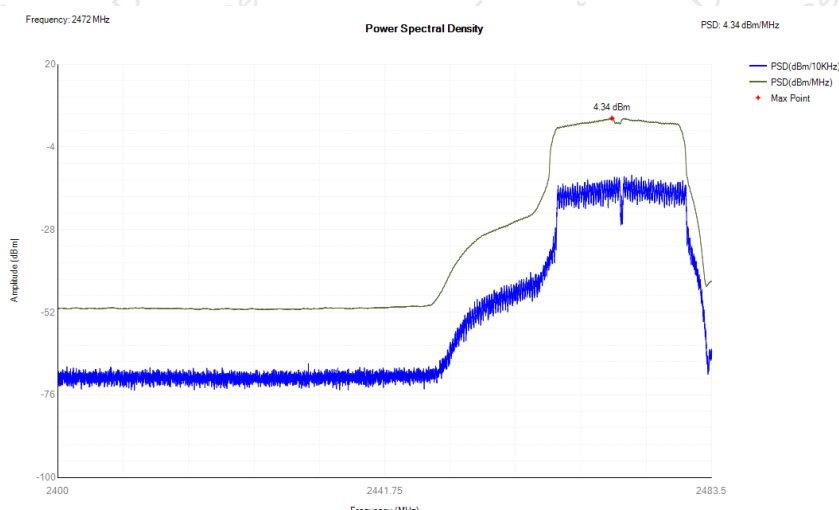
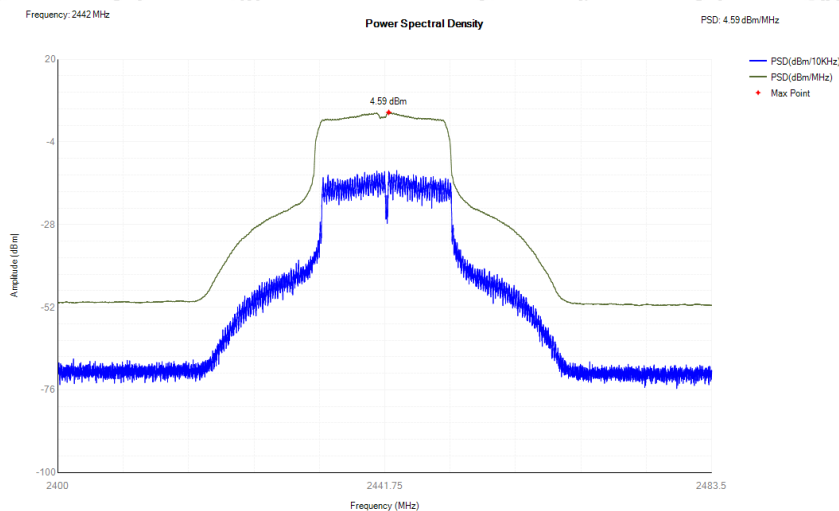
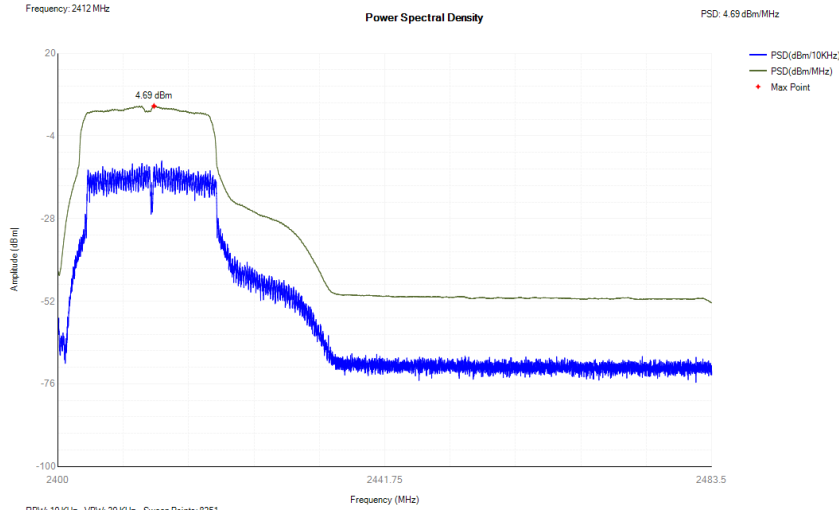



802.11g:

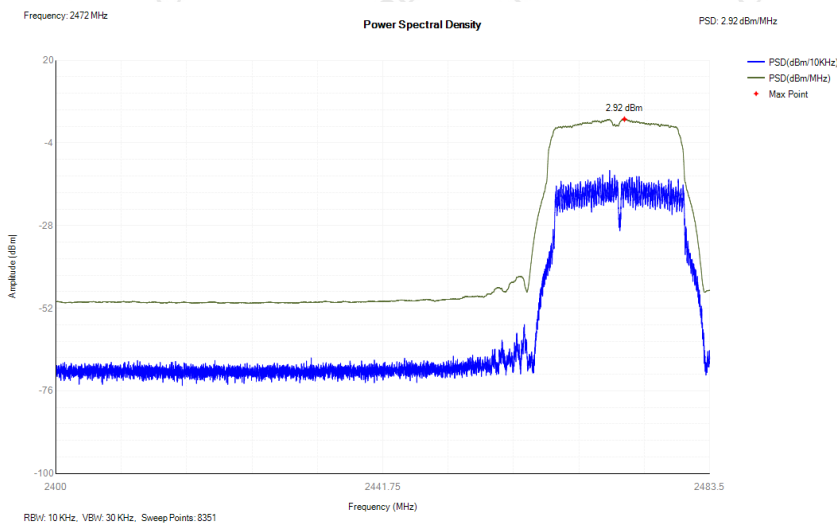
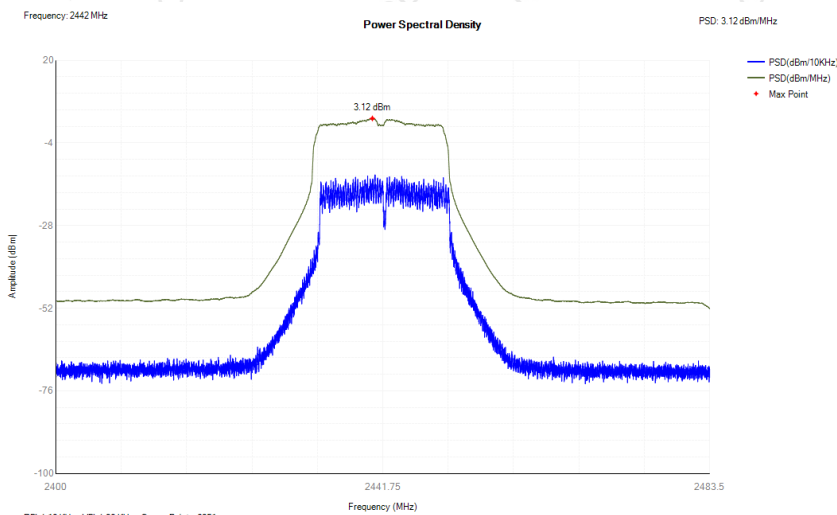
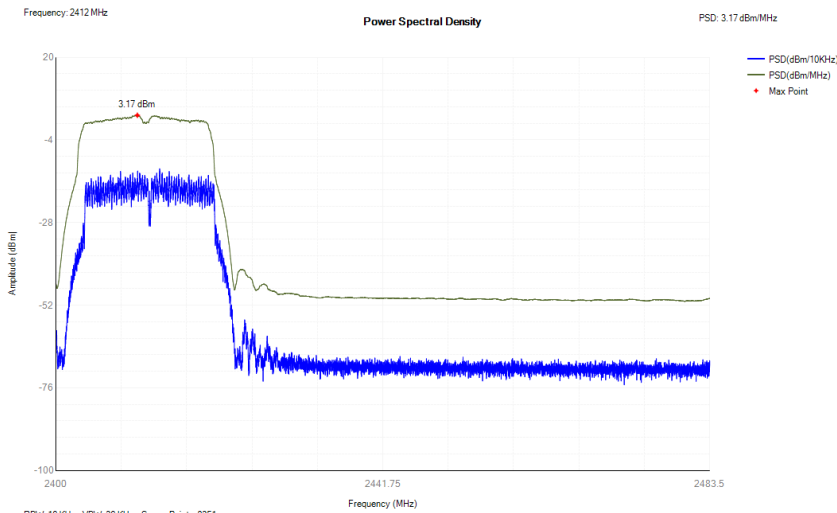



802.11n HT20:

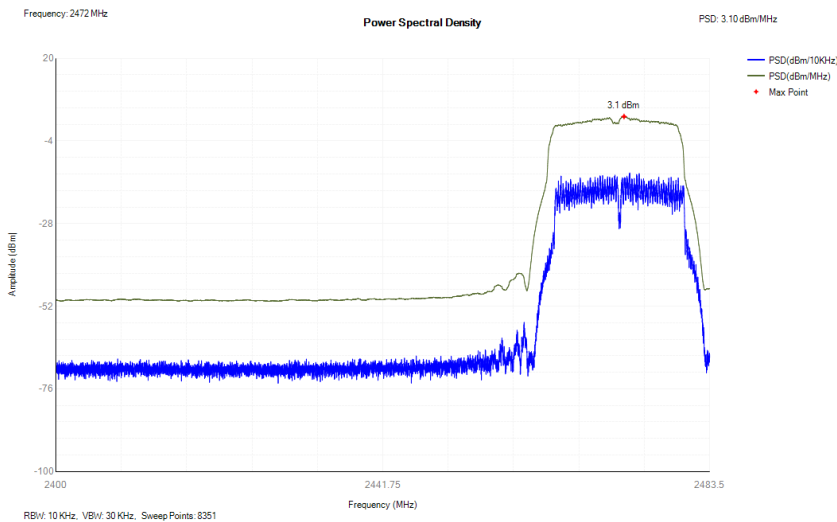
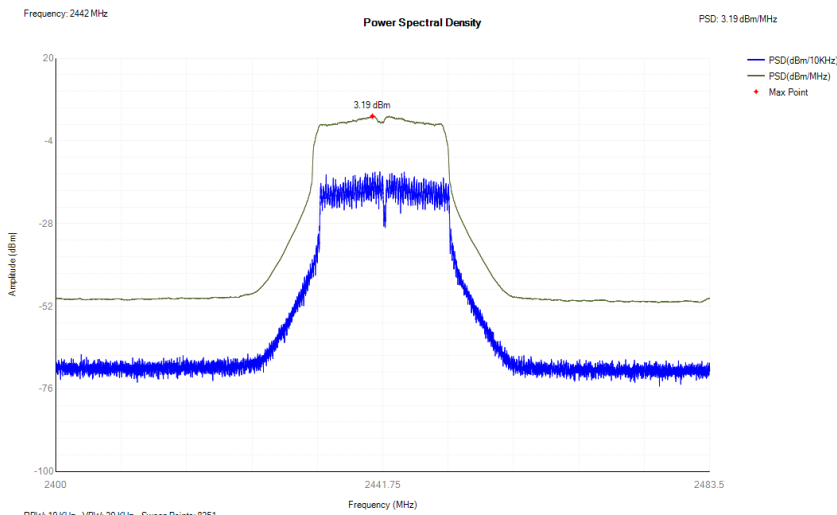
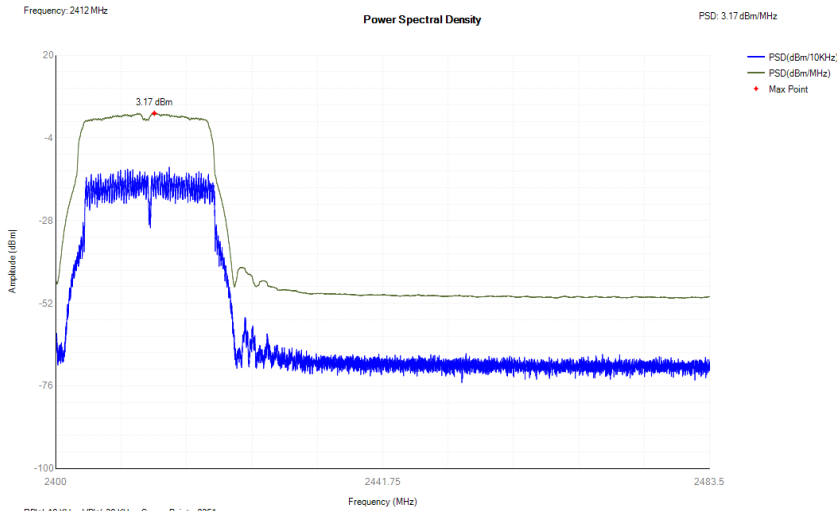



802.11n HT40 :

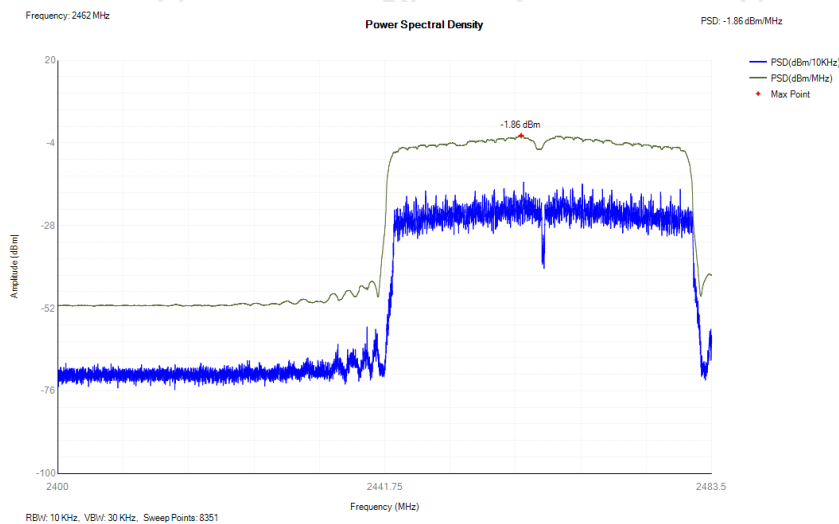
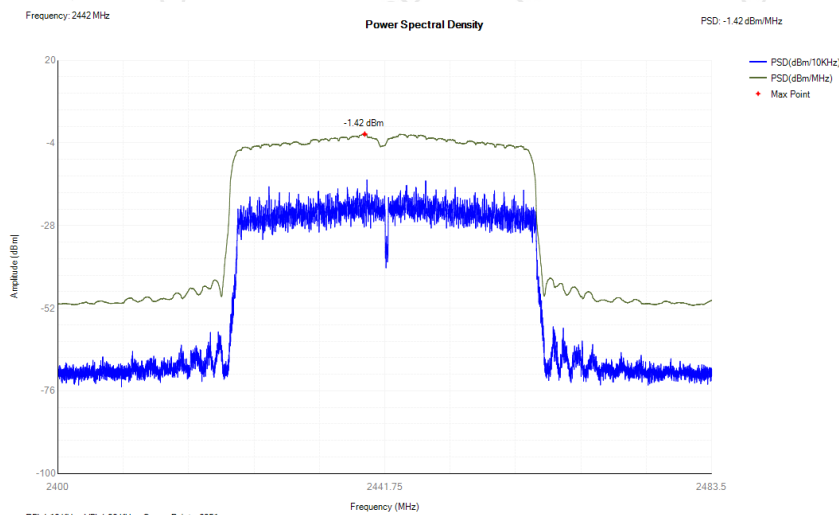
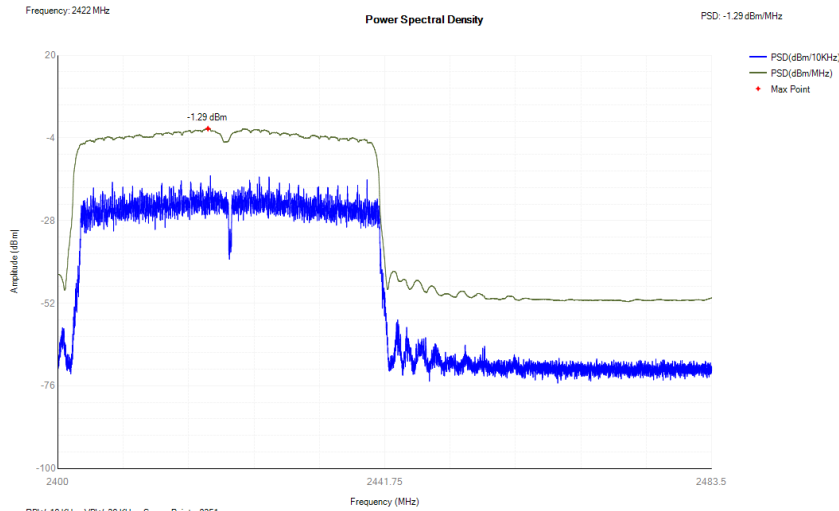



Antenna 2

802.11b:

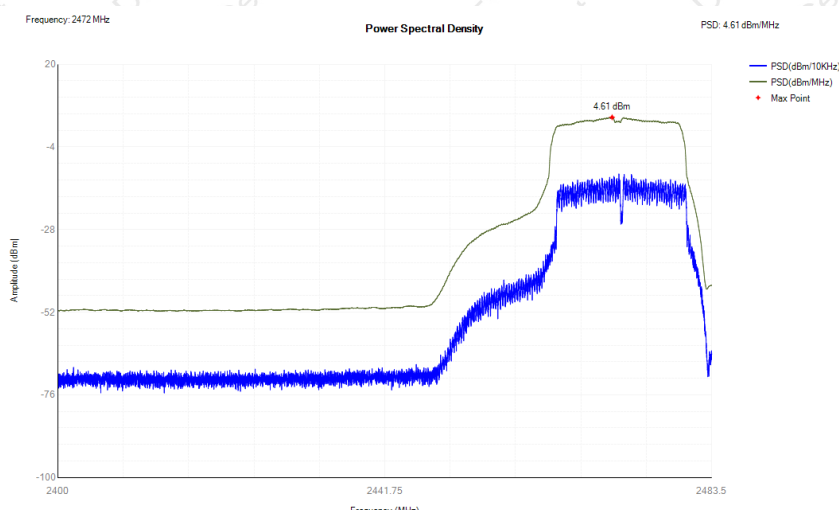
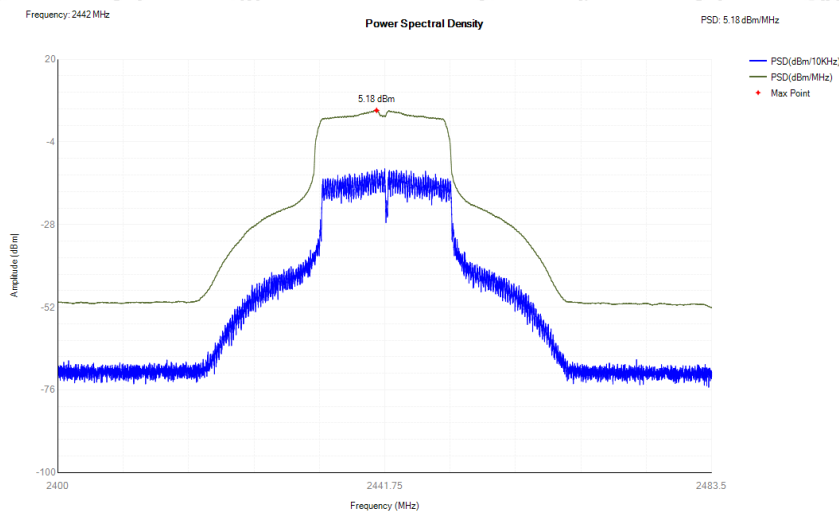
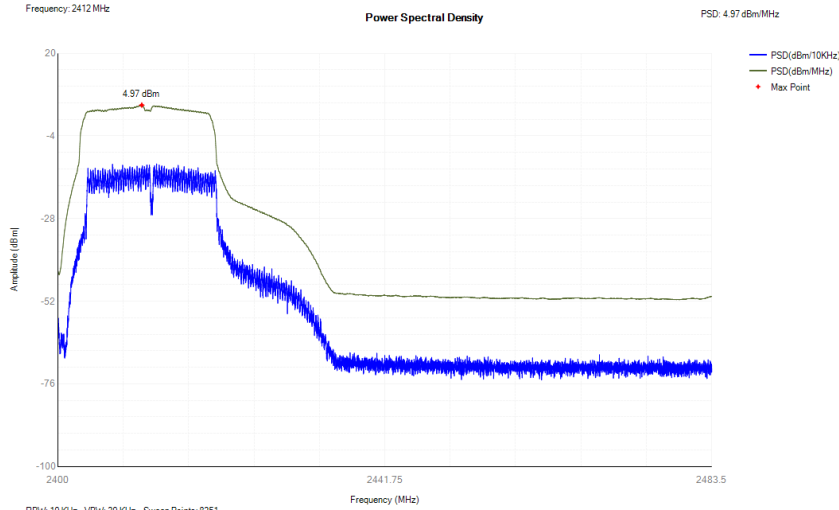



802.11g:

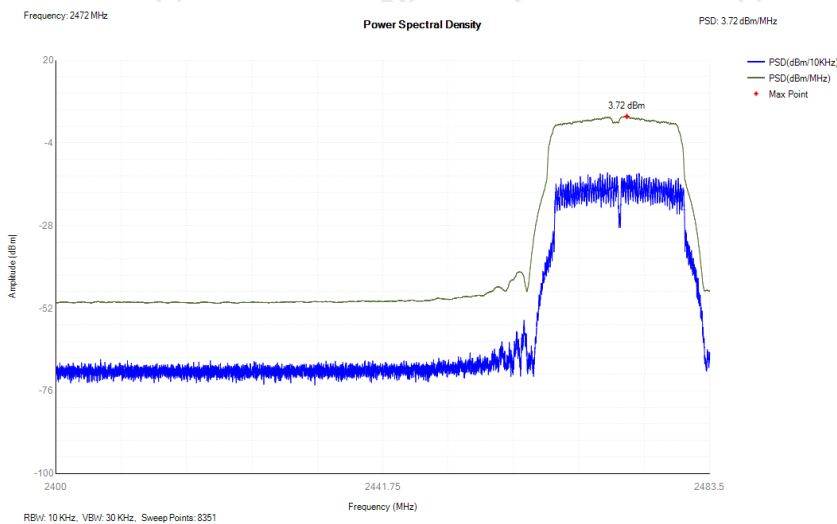
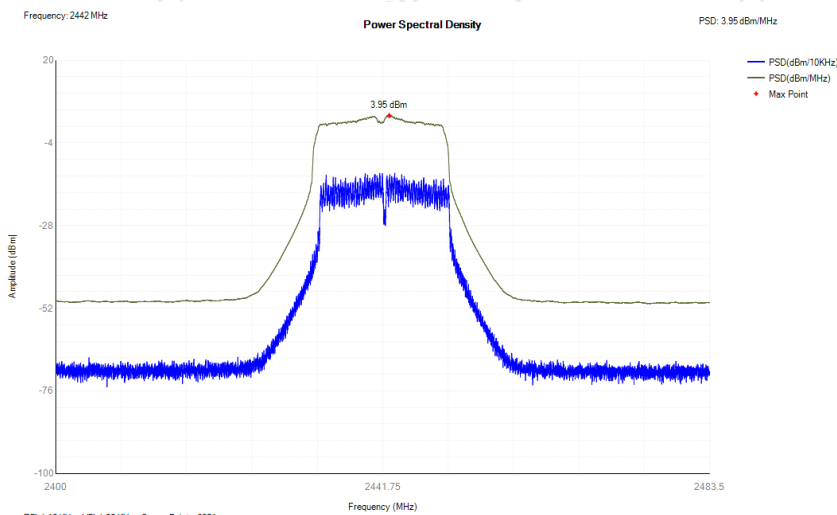
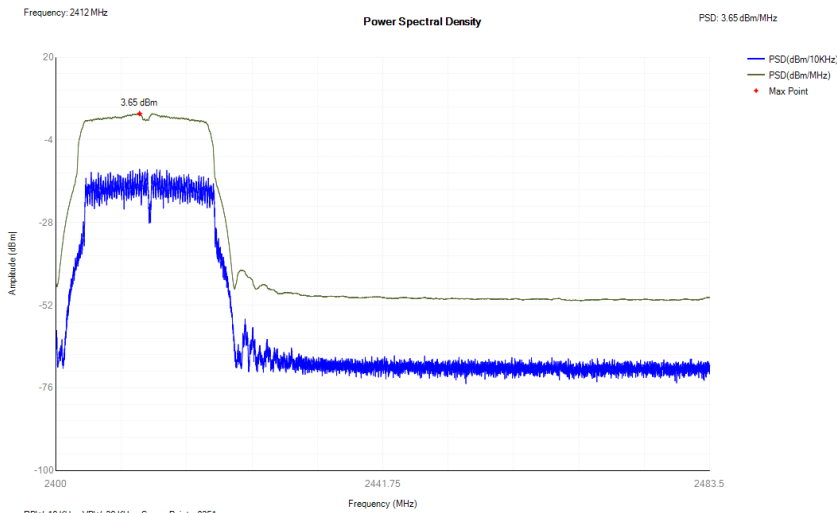



802.11n HT20:

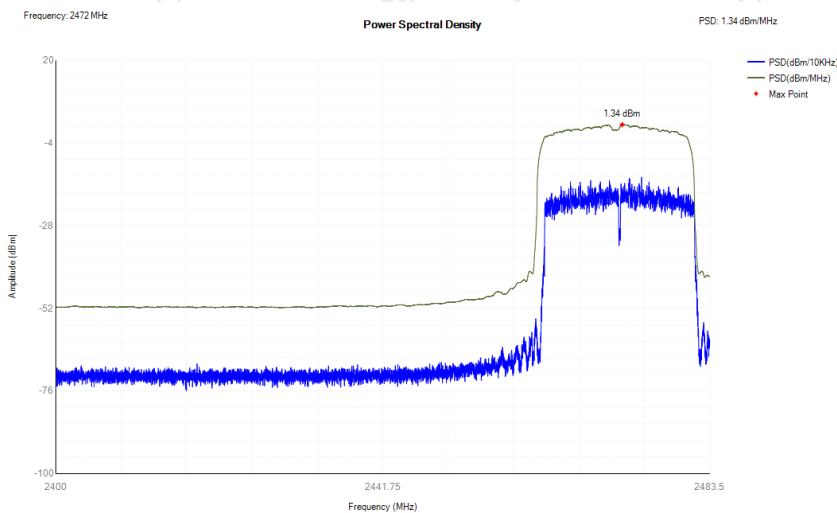
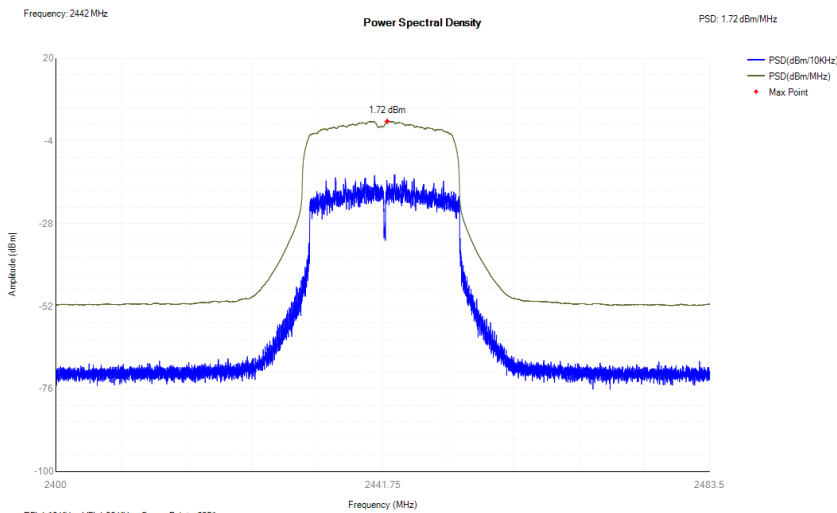
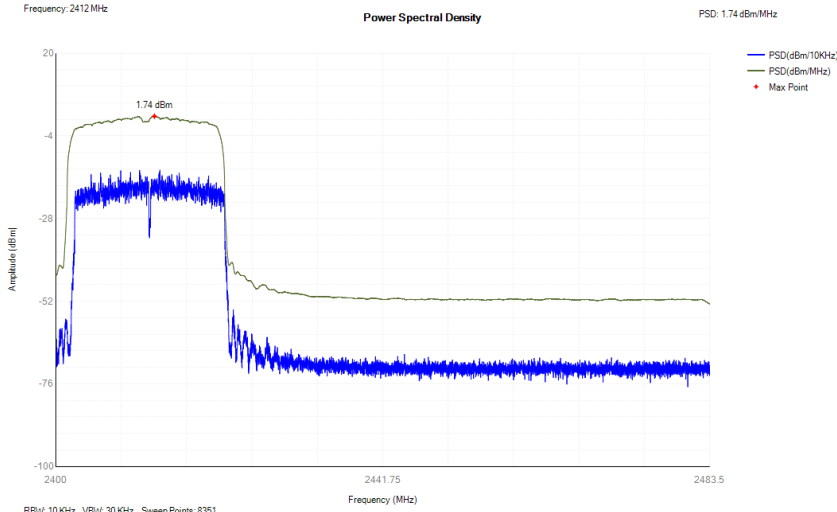



802.11n HT40 :

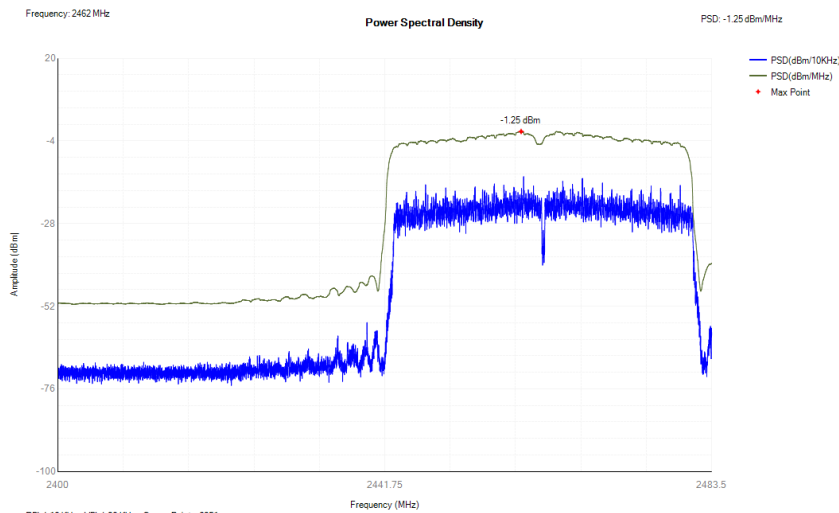
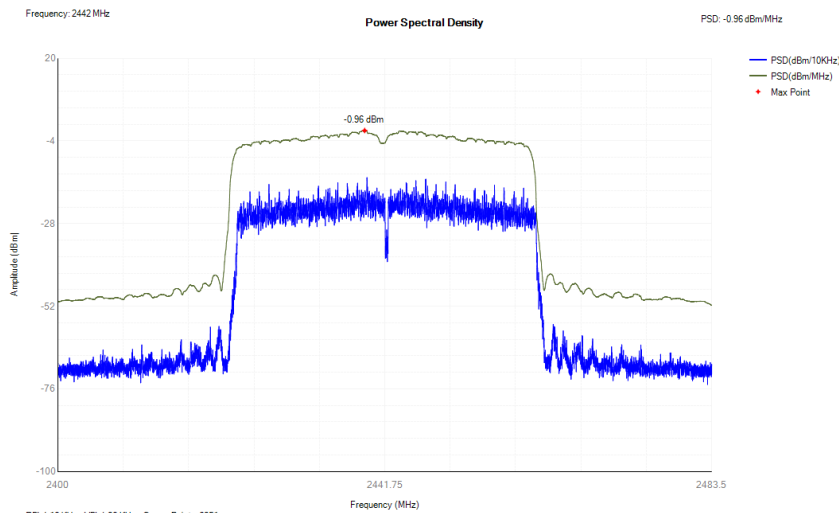
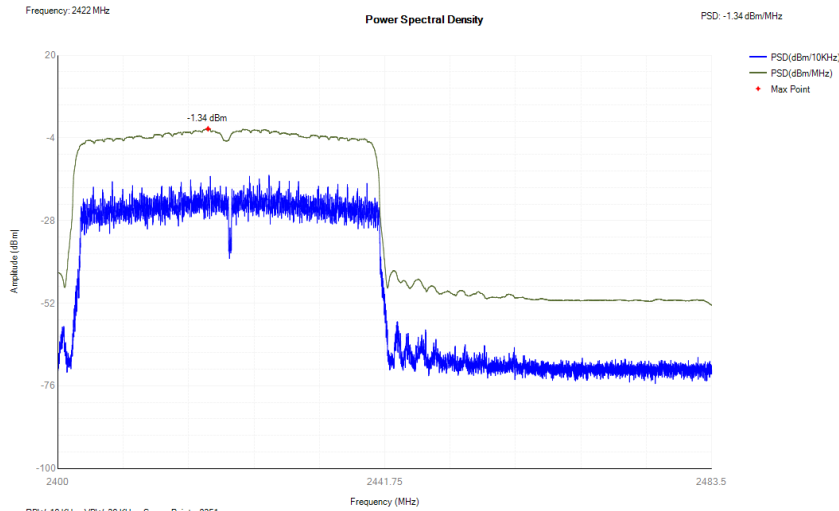

7. ADAPTIVITY

7.1 Block Diagram of Test Setup

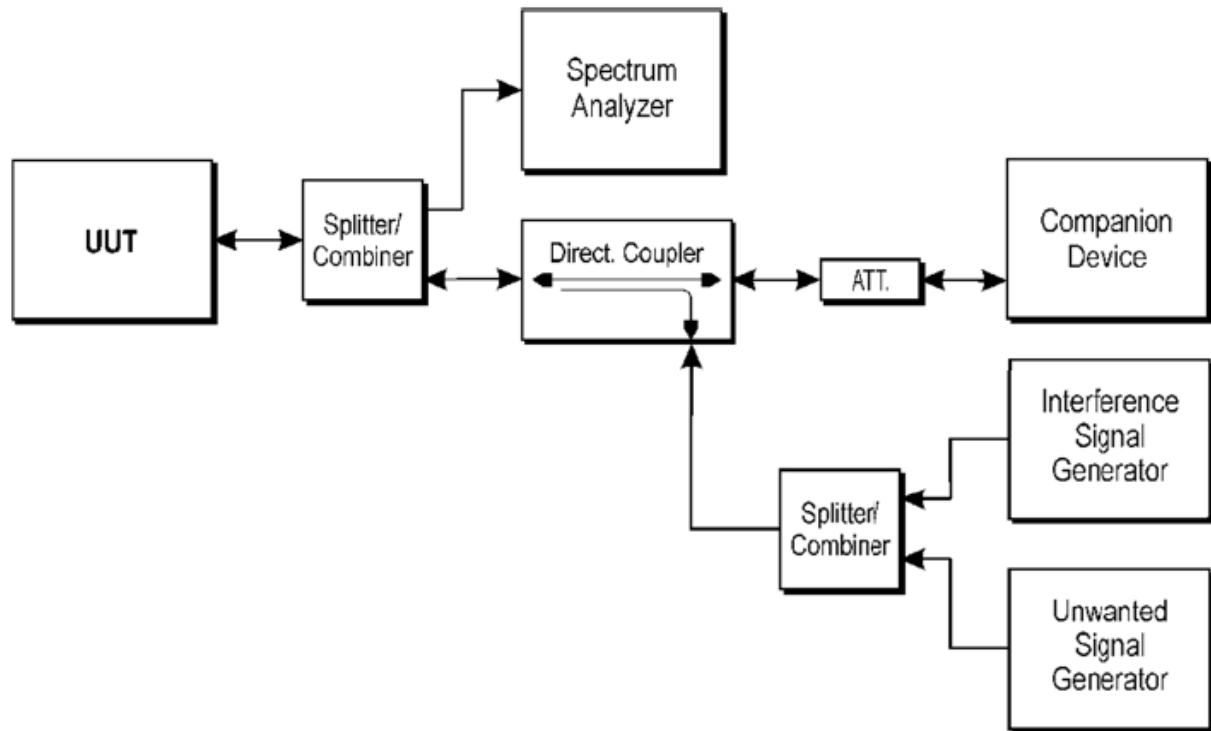

Figure 5: Test set-up for verifying the adaptivity of an equipment

7.2 Test Standard and Limit

Adaptive non-FHSS equipment using DAA shall comply with the following minimum set of requirements:

- 1) During normal operation, the equipment shall evaluate the presence of a signal on its current operating channel(s). If it is determined that a signal is present with a level above the detection threshold defined in step 5 that channel shall be marked as 'unavailable'.
- 2) The channel(s) shall remain unavailable for a minimum time equal to 1 s after which the channel may be considered again as an 'available' channel
- 3) The total time during which an equipment has transmissions on a given channel without re-evaluating the availability of that channel, is defined as the Channel Occupancy Time. The Channel Occupancy Time shall be less than 40 ms. Each such transmission sequence shall be followed by an Idle Period (no transmissions) of minimum 5 % of the Channel Occupancy Time with a minimum of 100 μ s. After this, the procedure as in step 1 needs to be repeated.
- 4) The detection threshold shall be proportional to the transmit power of the transmitter: for a 20 dBm e.i.r.p. transmitter the detection threshold level (TL) shall be equal to or less than -70 dBm/MHz at the input to the receiver assuming a 0 dBi (receive) antenna assembly. This threshold level (TL) may be corrected for the (receive) antenna assembly gain (G); however, beamforming gain (Y) shall not be taken into account. For power levels less than 20 dBm e.i.r.p., the detection threshold level may be relaxed to:

$$TL = -70 \text{ dBm/MHz} + 10 \times \log_{10} (100 \text{ mW} / P_{\text{out}}) \text{ (} P_{\text{out}} \text{ in mW e.i.r.p.)}$$

- 5) The equipment shall comply with the requirements defined in step 1 to step 4 of the present clause in the



presence of an unwanted CW signal as defined in table 9.

Table 9: Unwanted Signal parameters

Wanted signal mean power from companion device (dBm)	Unwanted signal frequency (MHz)	Unwanted CW signal power (dBm)
-30 (see note 2)	2 395 or 2 488,5 (see note 1)	-35 (see note 2)
<p>NOTE 1: The highest frequency shall be used for testing operating channels within the range 2 400 MHz to 2 442 MHz, while the lowest frequency shall be used for testing operating channels within the range 2 442 MHz to 2 483,5 MHz. See clause 5.4.6.1.</p> <p>NOTE 2: The level specified is the level at the UUT receiver input assuming a 0 dBi antenna assembly gain. In case of conducted measurements, this level has to be corrected for the (in-band) antenna assembly gain (G). In case of radiated measurements, this level is equivalent to a power flux density in front of the UUT antenna.</p>		

7.3 Test Procedure

Refer to ETSI EN 300 328 V2.2.2 Clause 5.4.6

7.4 Test Result

Test mode	Stop time after interfering signal(ms)	
Channel	Low	High
802.11b mode	173.95	179.62
802.11g mode	209.57	168.05
802.11n HT20 mode	209.57	168.00
802.11n HT40 mode	187.66	218.01
<p>Remark: 1: Short Control Signalling Transmissions of adaptive equipment using wide band modulations other than FHSS shall have a maximum duty cycle of 10 % within an observation period of 50 ms.</p> <p>2: Both Antenna 1 and Antenna 2 have been tested, and only the worst test result of Antenna 1 low channel is shown in the report.</p>		



Short Control Signalling Transmissions						
Test mode	Channel	Channel occupancy time (ms)	Idle time (ms)	Pulse width (ms)	Maximum duty cycle(%)	Conclusion
802.11b mode	Low	1.57	0.05	1.44	2.87	Pass
	High	1.42	0.11	1.41	2.82	Pass
802.11g mode	Low	1.24	0.05	1.235	2.466	Pass
	High	1.26	0.05	1.235	2.466	Pass
802.11n HT20 mode	Low	1.24	0.05	1.235	2.466	Pass
	High	1.26	0.05	1.235	2.466	Pass
802.11n HT40 mode	Low	1.71	0.05	1.663	3.326	Pass
	High	1.67	0.05	1.663	3.326	Pass

Note:

- 1.Channel occupancy time must between on 1.65ms to 13.25ms
2. Idle time must longer than 20us.
3. Duty cycle=Pulse time/50ms.
4. Short Control Signalling Transmissions of adaptive equipment using wide band modulations other than FHSS shall have a maximum duty cycle of 10 % within an observation period of 50ms.
5. Both Antenna 1 and Antenna 2 have been tested, and only the worst test result of Antenna 1 low channel is shown in the report.



802.11b Low channel

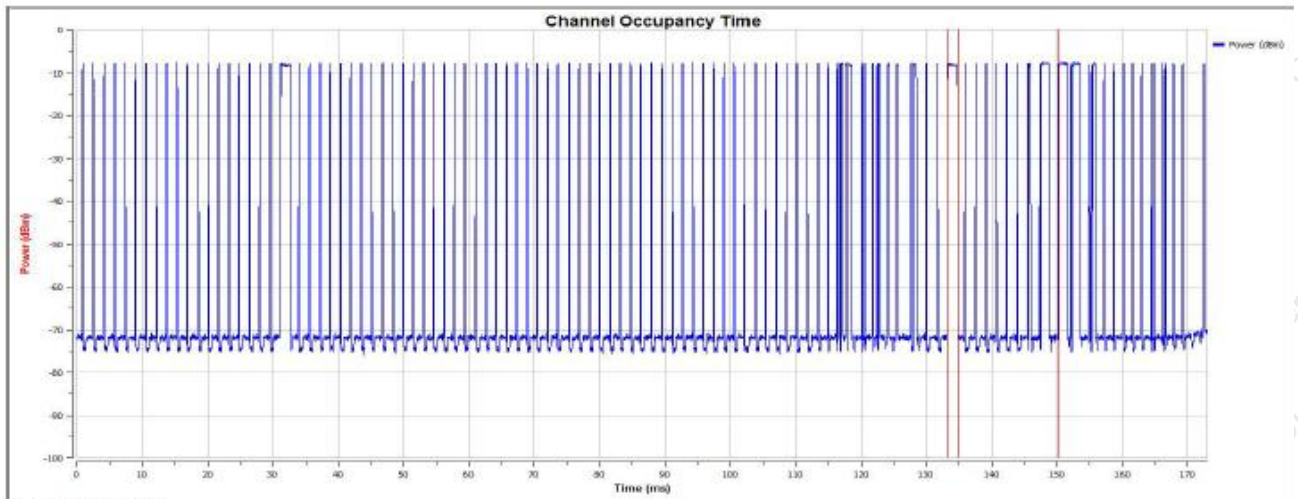
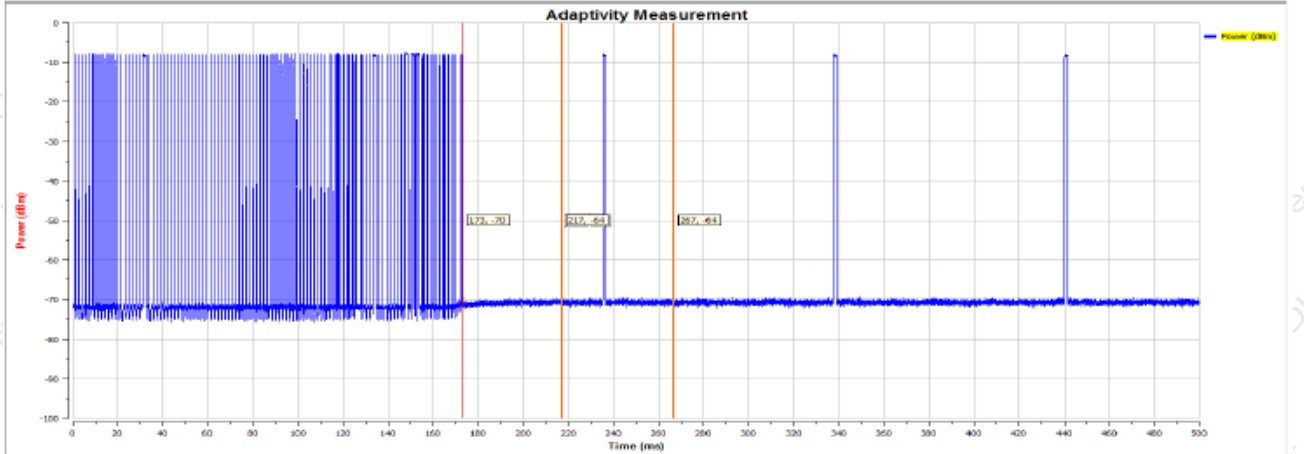

Channel Occupancy Time Info:
Maximum Channel Occupancy Time (ms) : 1.56
Minimum Channel Occupancy Time (ms) : 0.00
*COT Time must be between on 1.625ms to 13ms
Idle Time (ms) : 50.00
*Idle Time must longer than 20µs

Suggested q Number : 4

Idle Time / Max COT (%) : 3.23

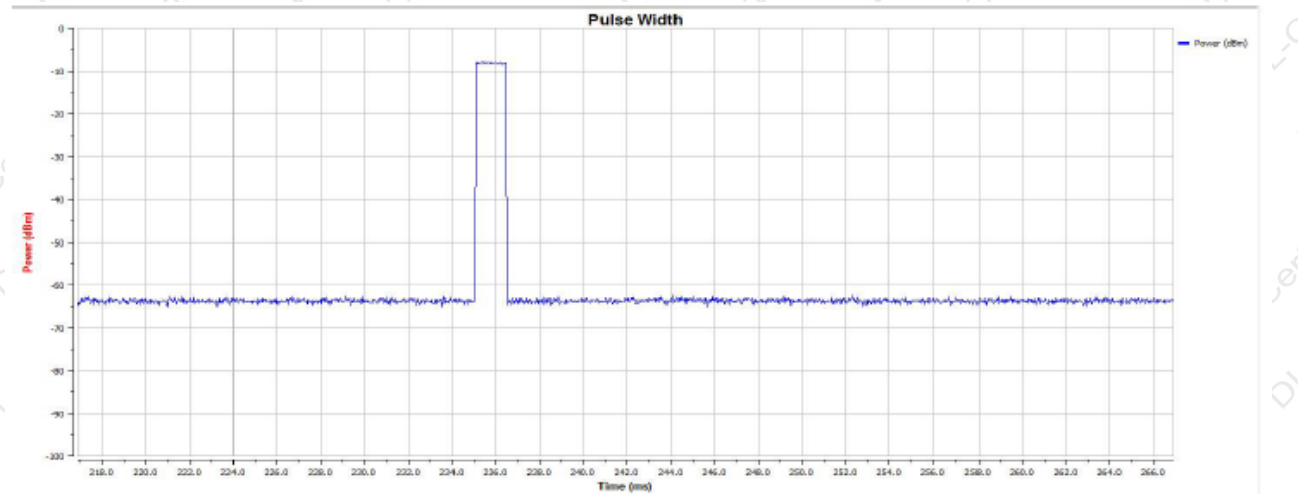

Pulse Width Info:

T1 (ms) : 216.93

T2 (ms) : 266.94

Pulse Width (ms) : 1.42500305175781

Duty Cycle (%) : 2.85000610351563



802.11b High channel

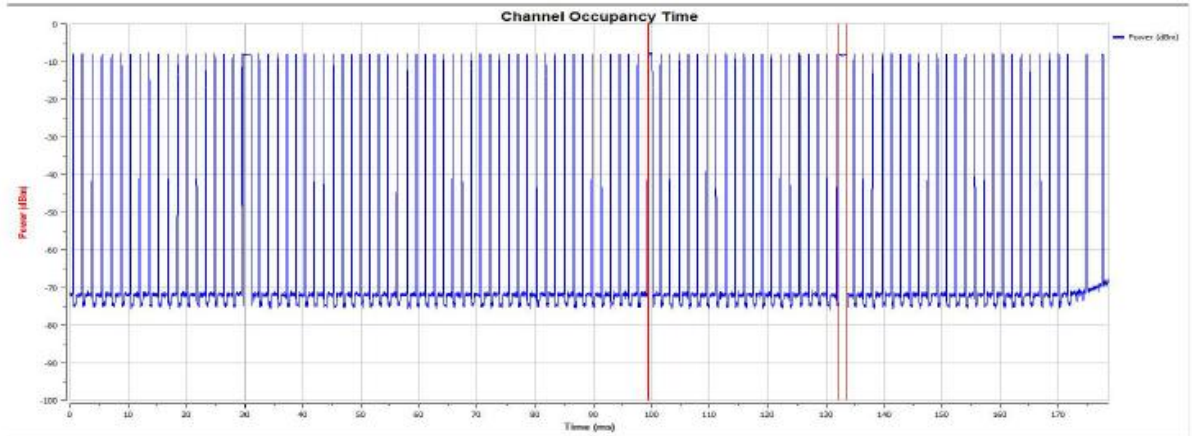
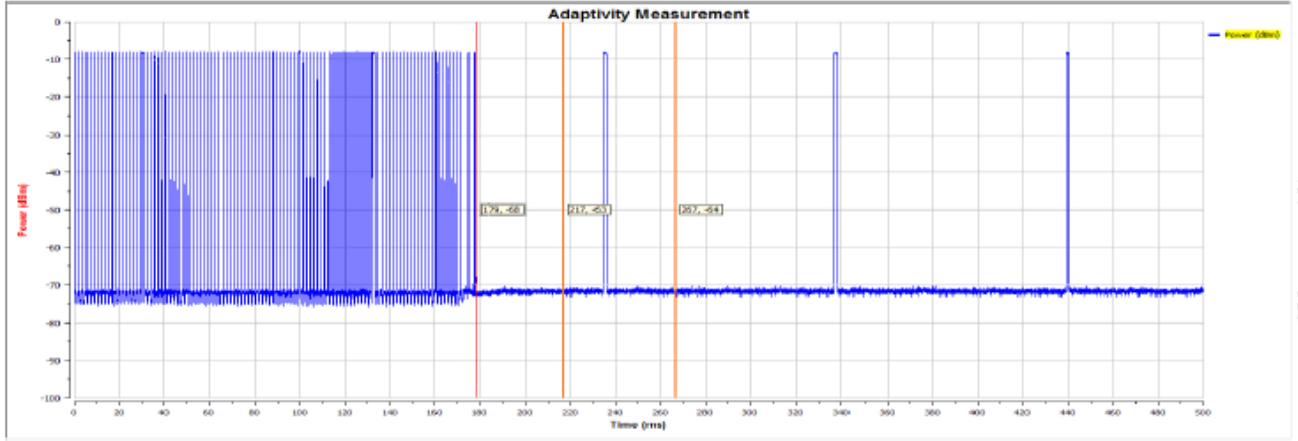

Channel Occupancy Time Info
Minimum Channel Occupancy Time (ms) : 1.00
Minimum Channel Occupancy Time (ms) : 0.00
*COT Time must between on 1.025ms to 10ms
Idle Time (ms) : 100.00
*Idle Time must longer than 20us

Suggested q Number : 3

Idle Time / Max COT (%) : 7.14

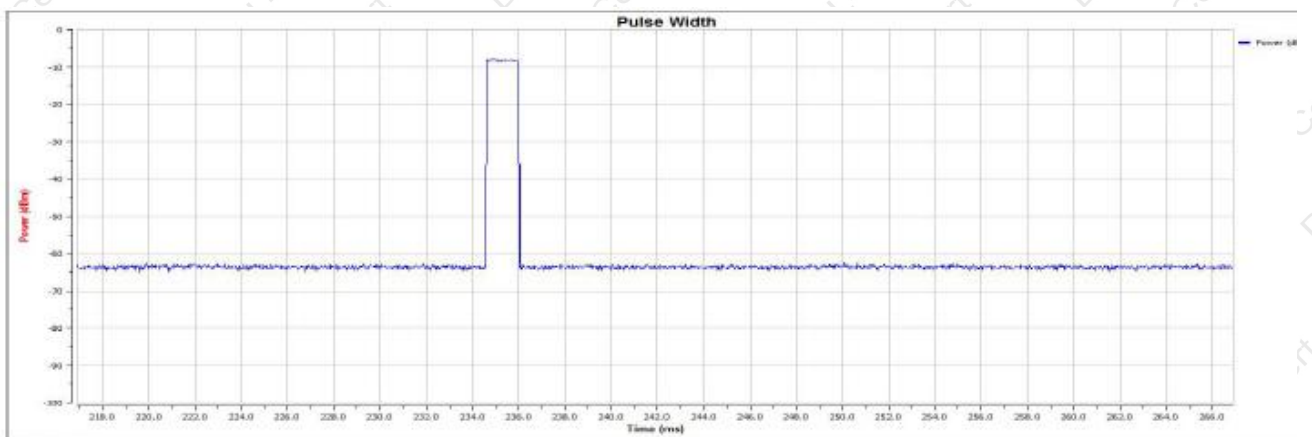

Pulse Width Info
T1 (ms) : 216.01
T2 (ms) : 266.01

Pulse Width (ms) : 2.0000000000000000
Duty Cycle (%) : 2.7999997792000000



802.11g Low channel

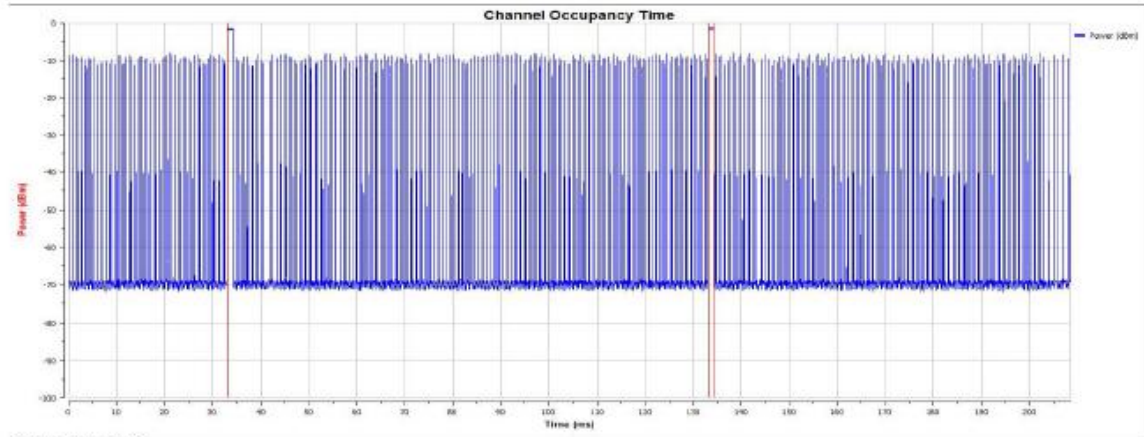
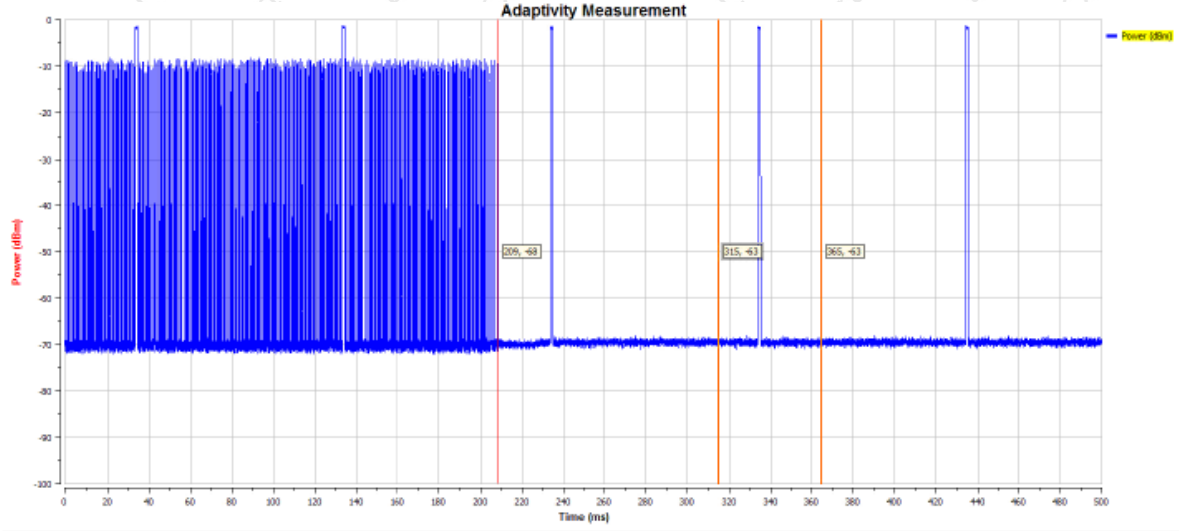

Channel Occupancy Time Info
 Maximum Channel Occupancy Time (ms) : 1.00
 Minimum Channel Occupancy Time (ms) : 0.00
 *COT Time must between 0.001ms to 10ms
 Idle Time (ms) : 50.00
 *Idle Time must longer than 20us

Suggested q Number : 3

Idle Time / Max COT (%) : 4.08

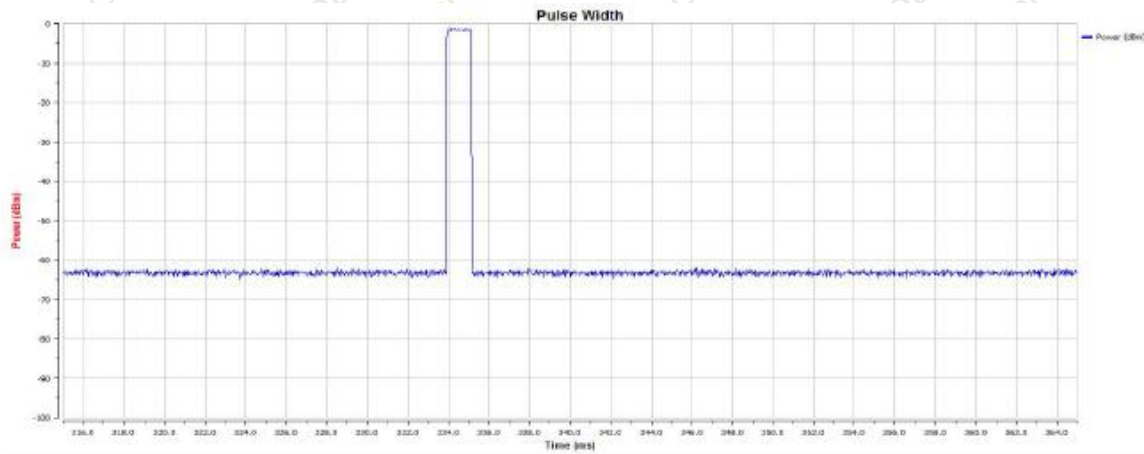

Pulse Width Info
 T1 (ms) : 224.89
 T2 (ms) : 246.89

Pulse Width (ms) : 2.2250000000000003

Duty Cycle (%) : 2.49801200705125



802.11g High channel

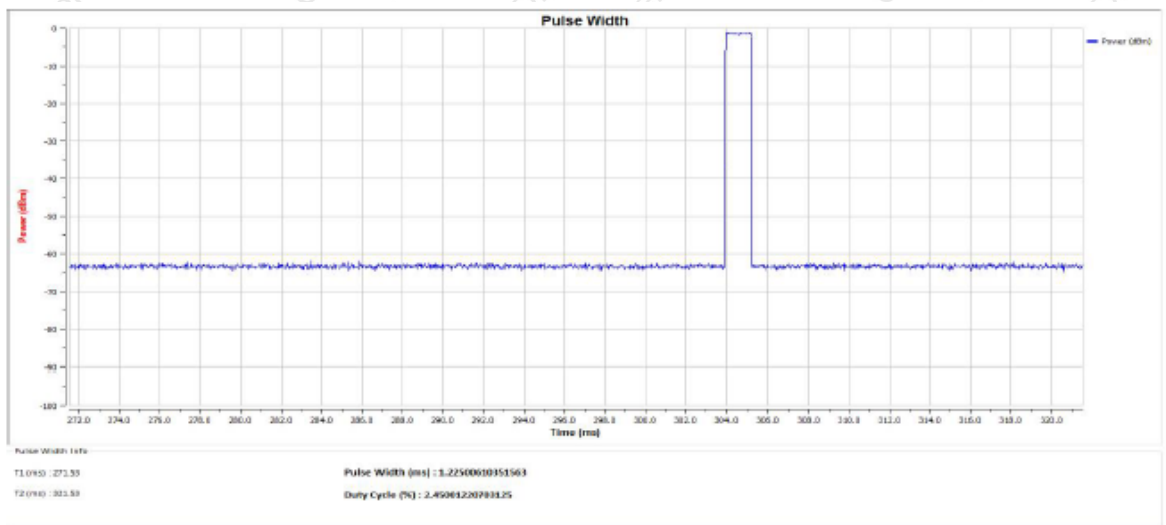
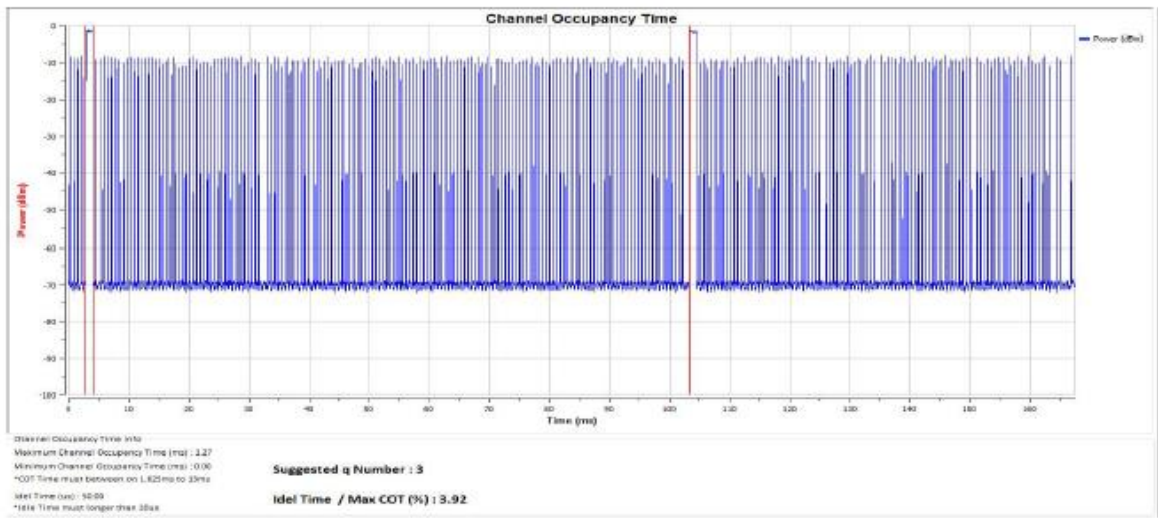
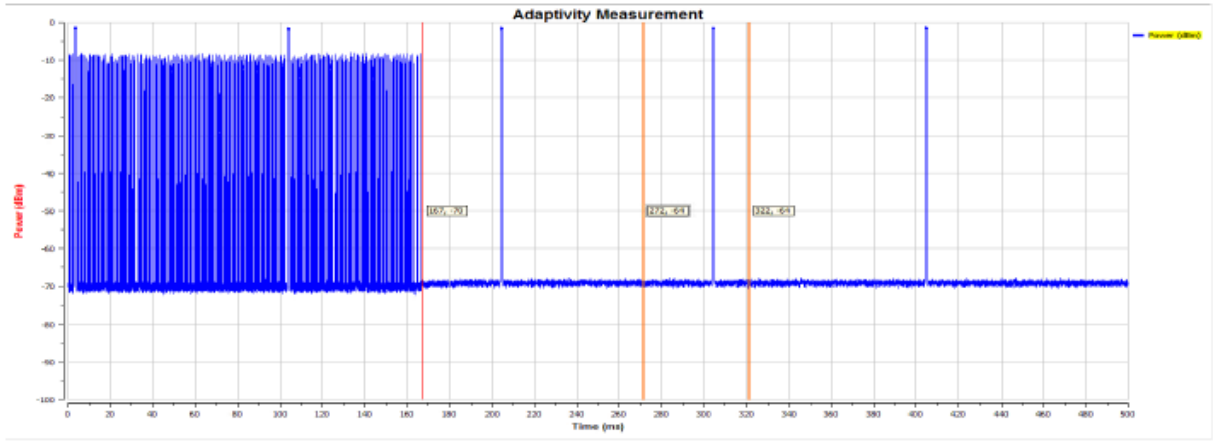



802.11n HT20 Low channel

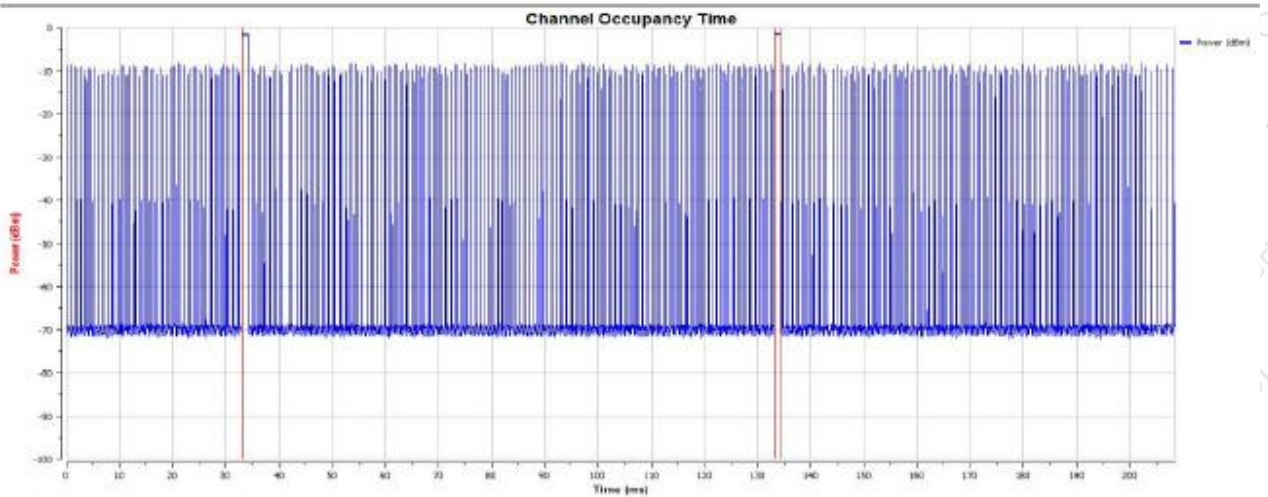
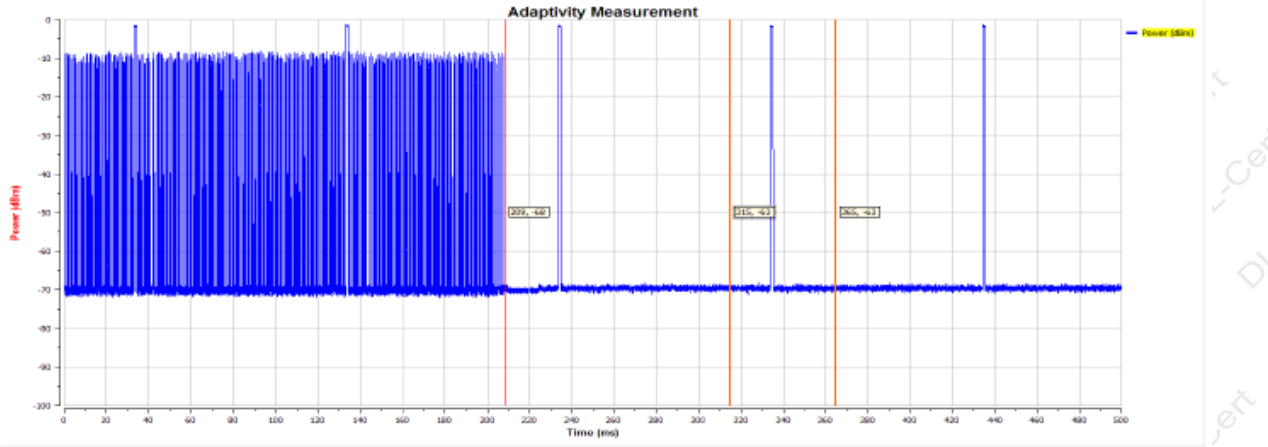

Channel Occupancy Time info
Maximum Channel Occupancy Time (ms) : 1.25
Minimum Channel Occupancy Time (ms) : 0.00
*COT Time must between in 1.015ms to 13ms
Idle Time (us) : 50.00
*Idle Time must longer than 20us

Suggested q Number : 3
Idle Time / Max COT (%) : 4.08

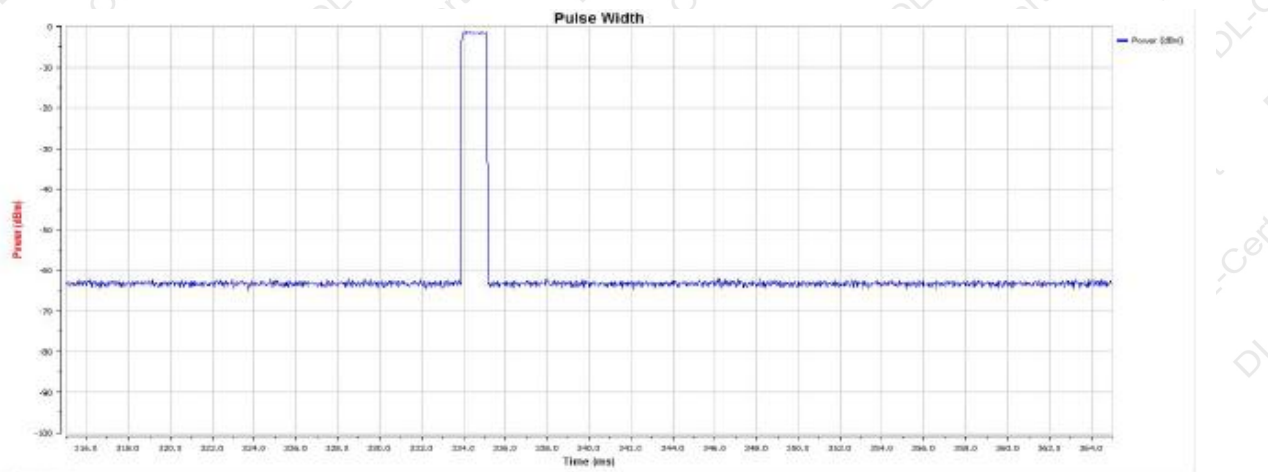

Pulse Width info
T1 (ns) : 235.89
T2 (ns) : 240.89
Pulse Width (ns) : 1.2350008893563
Duty Cycle (%) : 2.4596122970325



802.11n HT20 High channel

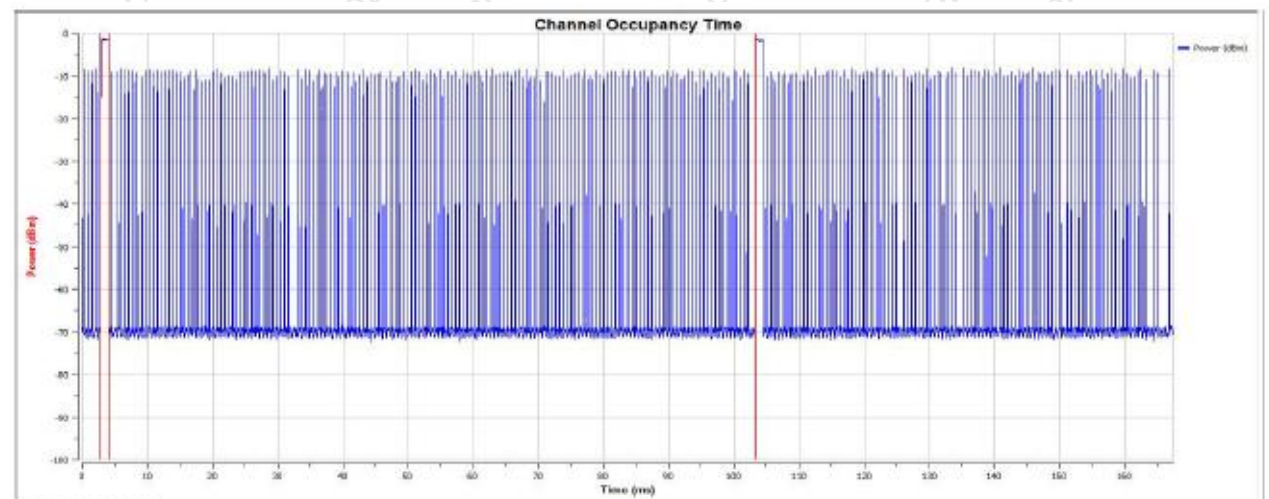
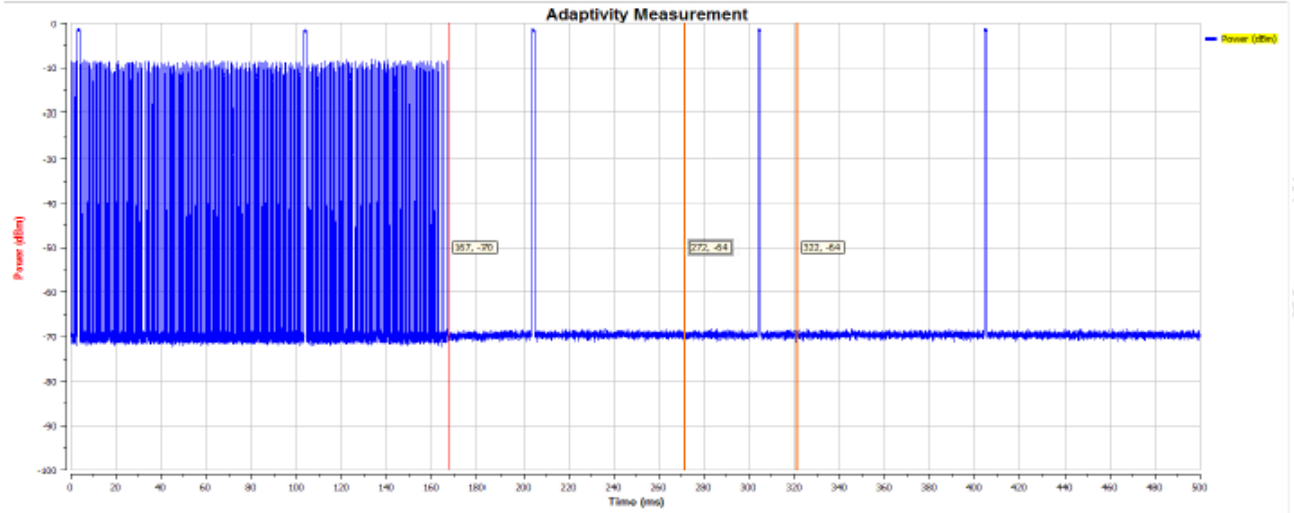

Channel Occupancy Time (ms):
Maximum Channel Occupancy Time (ms): 1.27
Minimum Channel Occupancy Time (ms): 0.00
*COT Time must be between 0.182ms to 25ms
Idle Time (ms): 32.00
*Idle Time must longer than 35ms

Suggested q Number : 3

Idle Time / Max COT (%) : 3.92

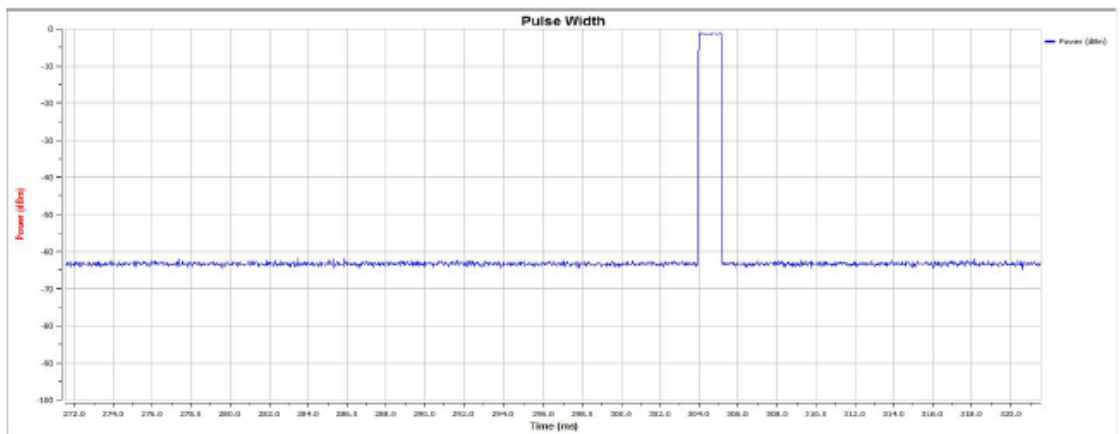

Pulse Width (ms):
T1 (ms): 271.55
T2 (ms): 323.55

Pulse Width (ms) : 5.22500010351563

Duty Cycle (%) : 2.4998220793325



802.11n HT40 Low channel

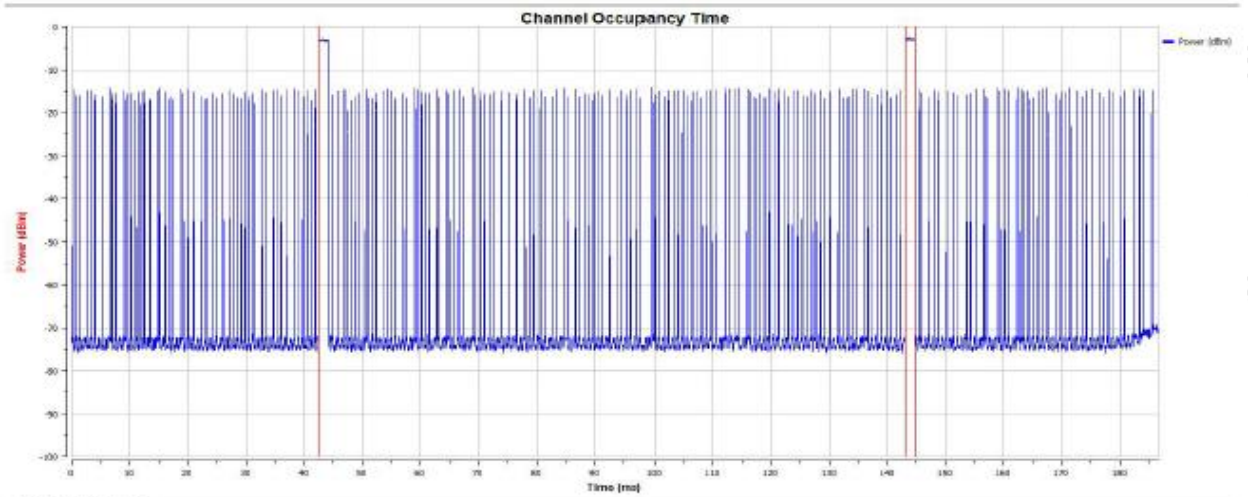
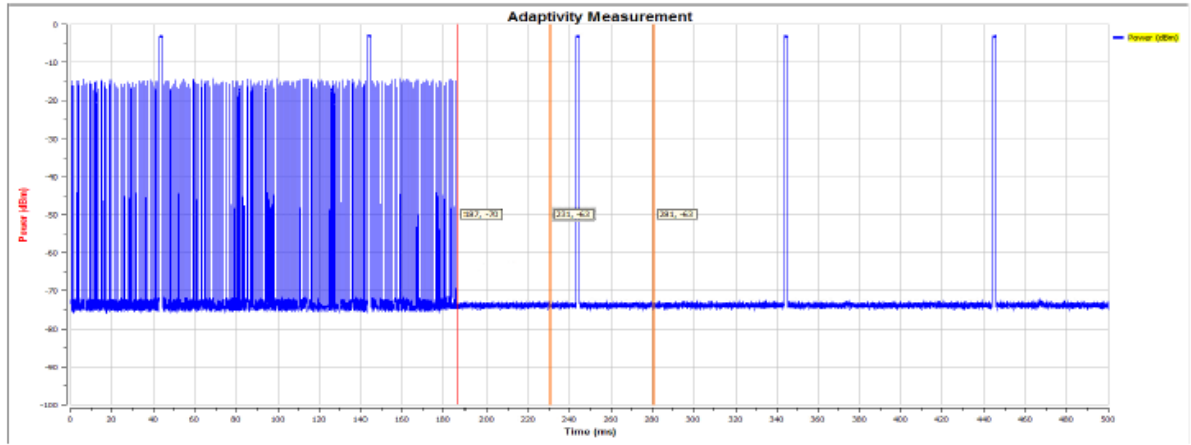

Channel Occupancy Time Info
Maximum Channel Occupancy Time (ms) : 1.10
Minimum Channel Occupancy Time (ms) : 0.00
*COT Time meas between on 1.82ms to 13ms
Idle Time (us) : 50.00
*Idle Time must larger than 20us

Suggested q Number : 4

Idle Time / Max COT (%) : 2.94

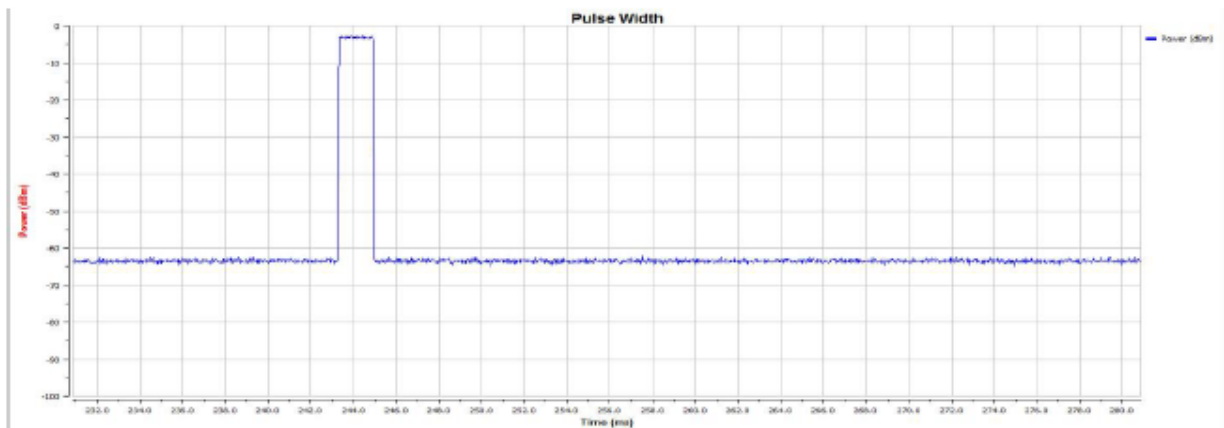

Pulse Width Info
T1 (ns) : 200.88
T2 (ns) : 200.88

Pulse Width (ms) : 1.6499938964438
Duty Cycle (%) : 3.29998779296675



802.11n HT40 High channel

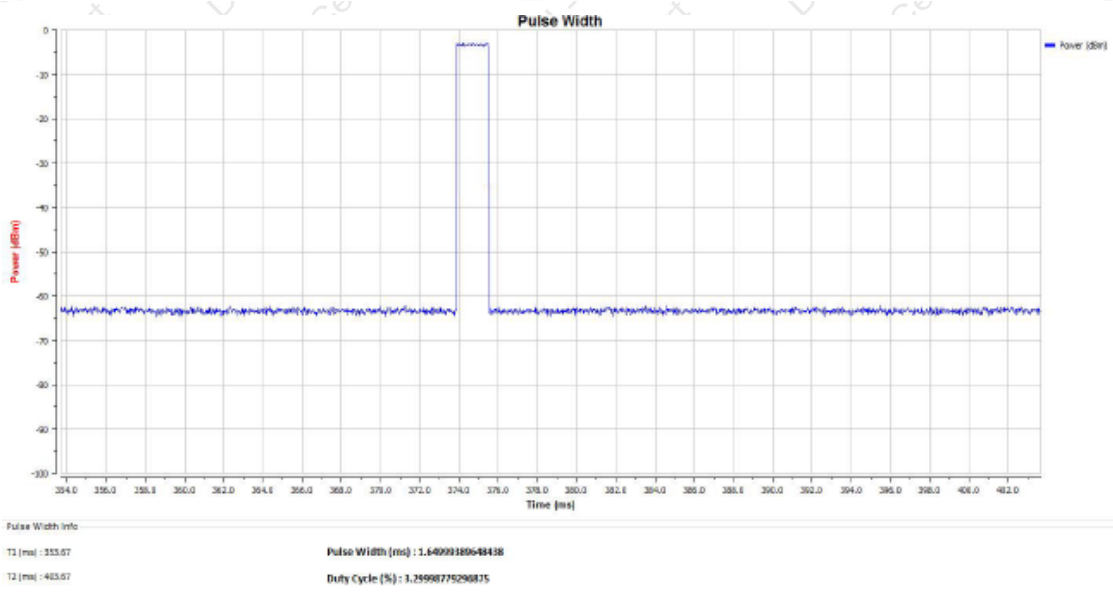
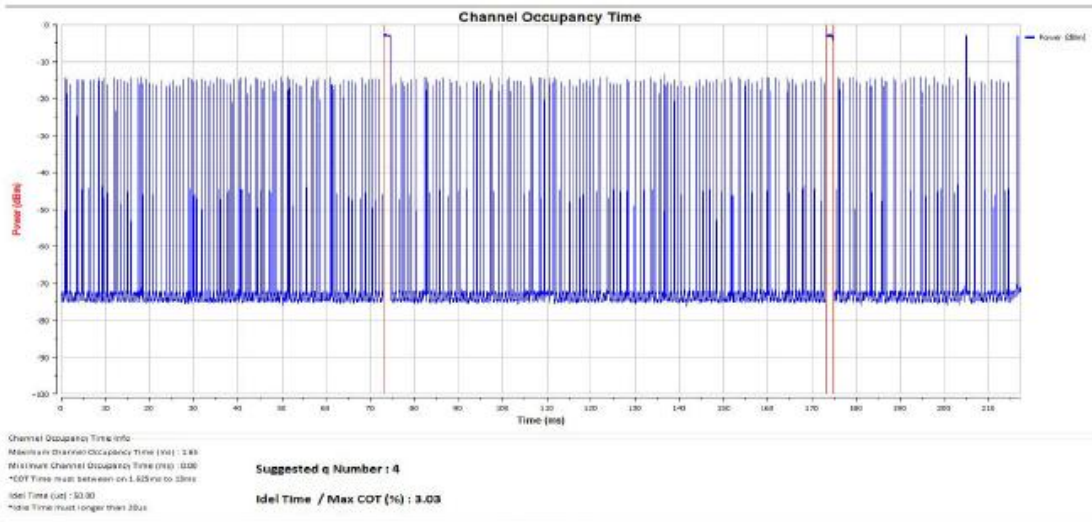
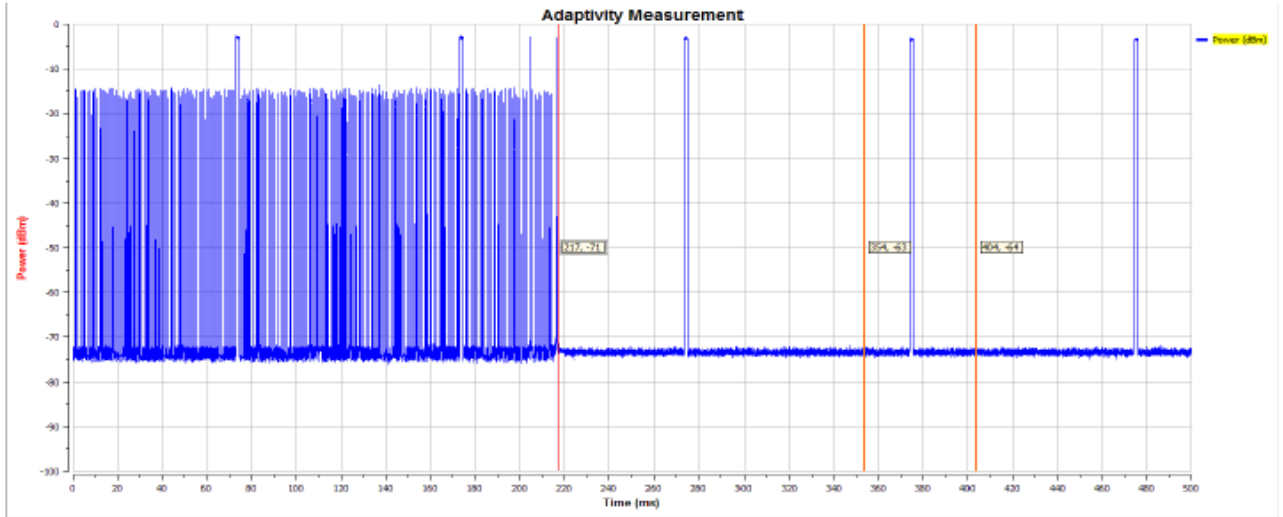



8. OCCUPIED CHANNEL BANDWIDTH

8.1 Block Diagram of Test Setup

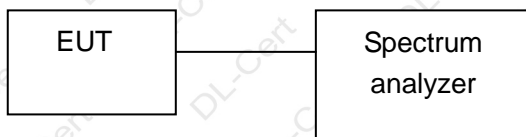

8.2 Test Standard and Limit

The Occupied Channel Bandwidth shall be within the band given in 2.4GHz to 2.4835GHz..

In addition, for non-adaptive non-FHSS equipment with e.i.r.p. greater than 10 dBm, the Occupied Channel Bandwidth shall be equal to or less than 20MHz.

8.3 Test Procedure

Refer to ETSI EN 300 328 V2.2.2 Clause 5.4.7

Connect the UUT to the spectrum analyzer and use the following settings:

Centre Frequency:	The centre frequency of the channel under test
RBW	~ 1 % of the span without going below 1 %
VBW	3 × RBW
Frequency Span:	2 × Nominal Channel Bandwidth
Detector Mode:	RMS
Trace Mode:	Max Hold
Sweep time:	1s

8.4 Test Result

Test Mode	Test Channel	Occupied Bandwidth	Measured Frequency		Limit	Result
			F _L (MHz)	F _H (MHz)		
802.11b	Low	16.591	2403.701	/	>2400MHz And <2483.5MHz	Pass
	High	16.599	/	2480.298		Pass
802.11g	Low	16.542	2403.728	/		Pass
	High	16.507	/	2480.259		Pass
802.11n HT20	Low	16.535	2403.728	/		Pass
	High	16.498	/	2480.255		Pass
802.11n HT40	Low	37.633	2403.191	/		Pass
	High	37.610	/	2480.804		Pass

Note1: Both Antenna 1 and Antenna 2 have been tested, and only the worst test result of Antenna 1 low channel is shown in the report.



802.11b

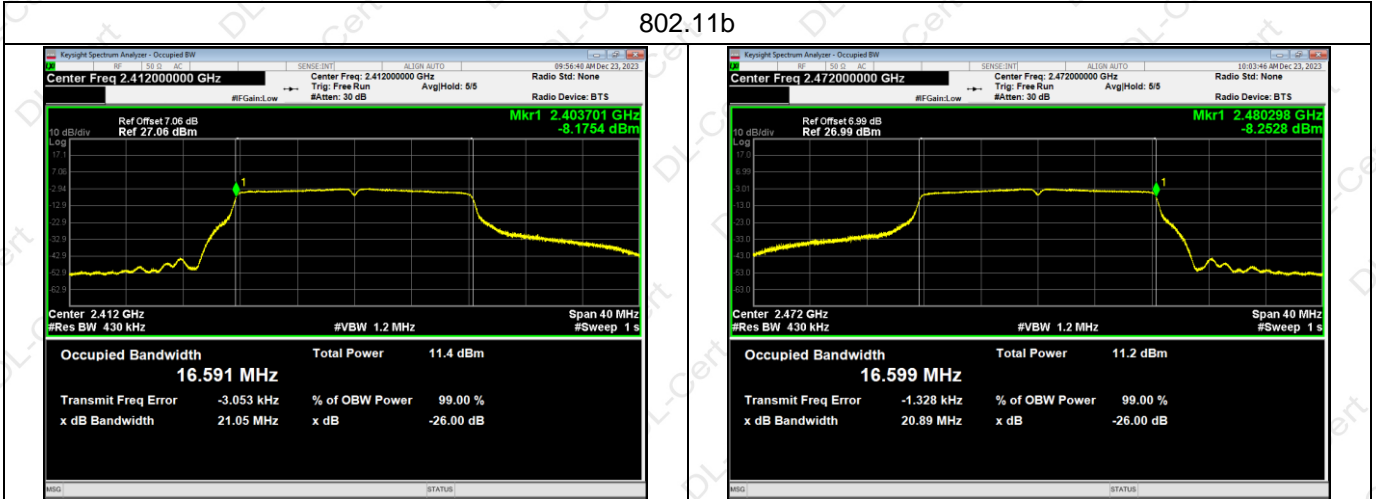

802.11g

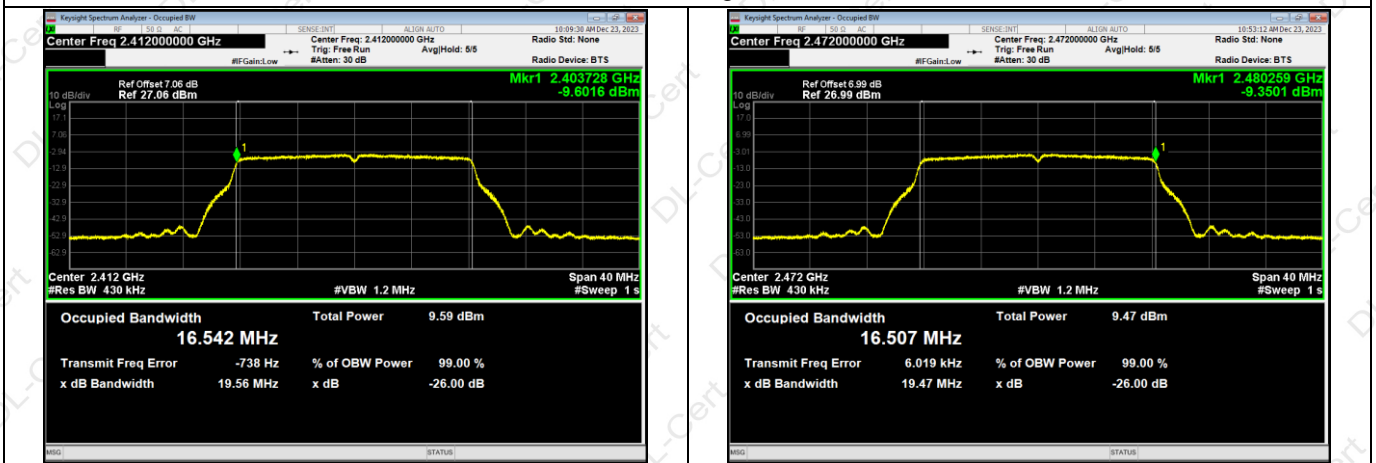



802.11n HT20

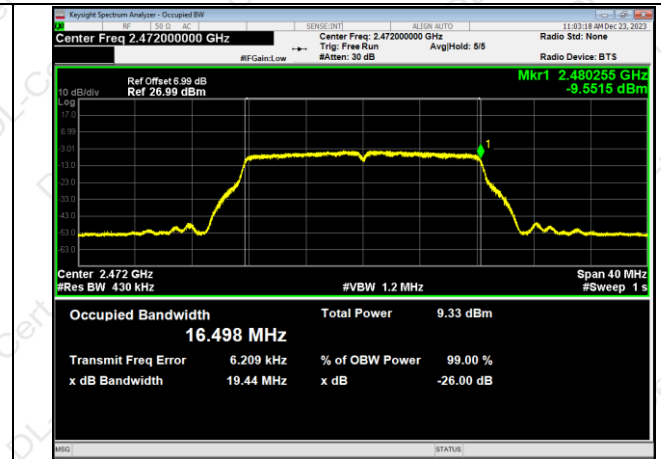
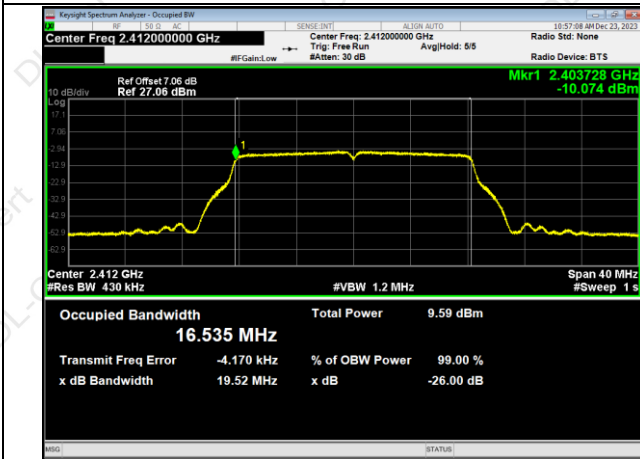

802.11n HT40

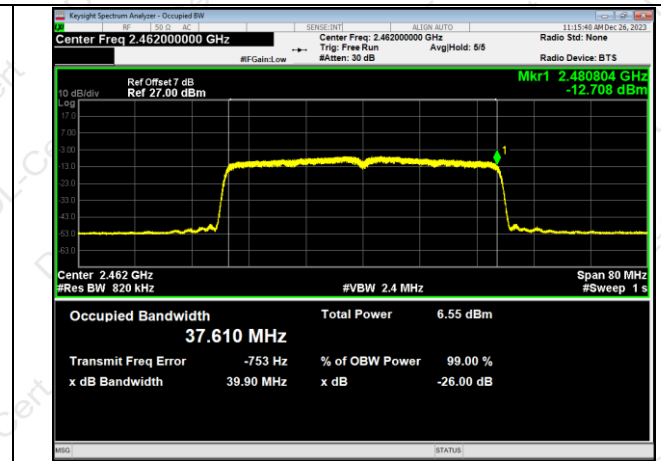
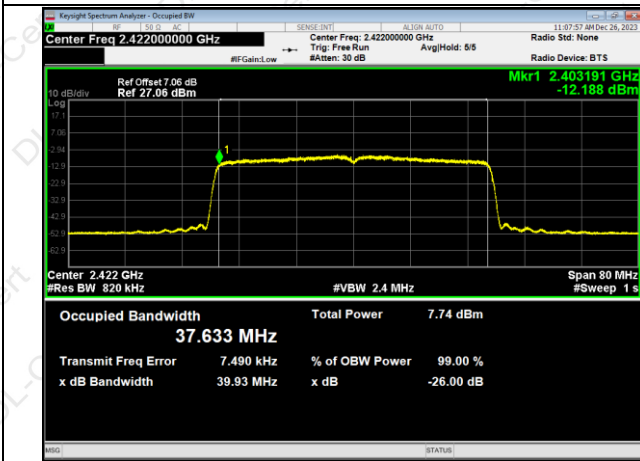

9. TRANSMITTER UNWANTED EMISSIONS IN THE OUT-OF-BAND DOMAIN

9.1 Block Diagram of Test Setup

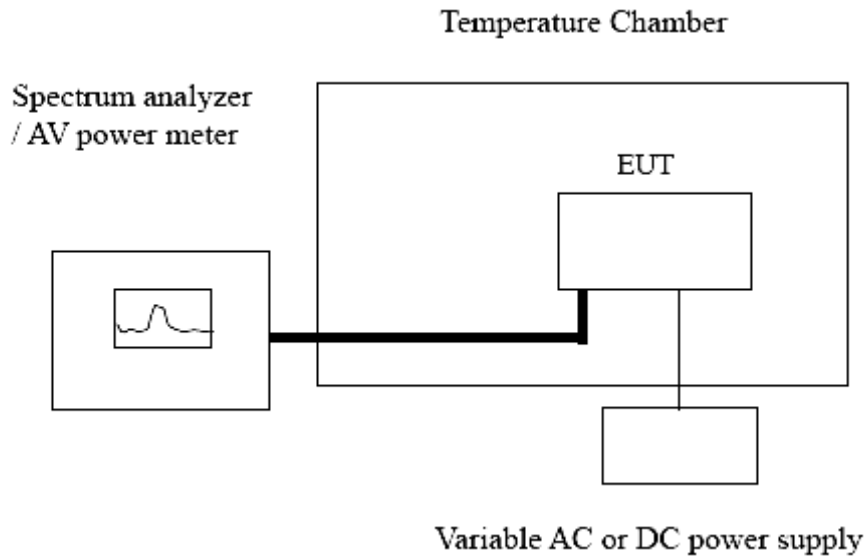

9.2 Test Standard and Limit

The transmitter unwanted emissions in the out-of-band domain shall not exceed the values provided by the mask in figure 3.

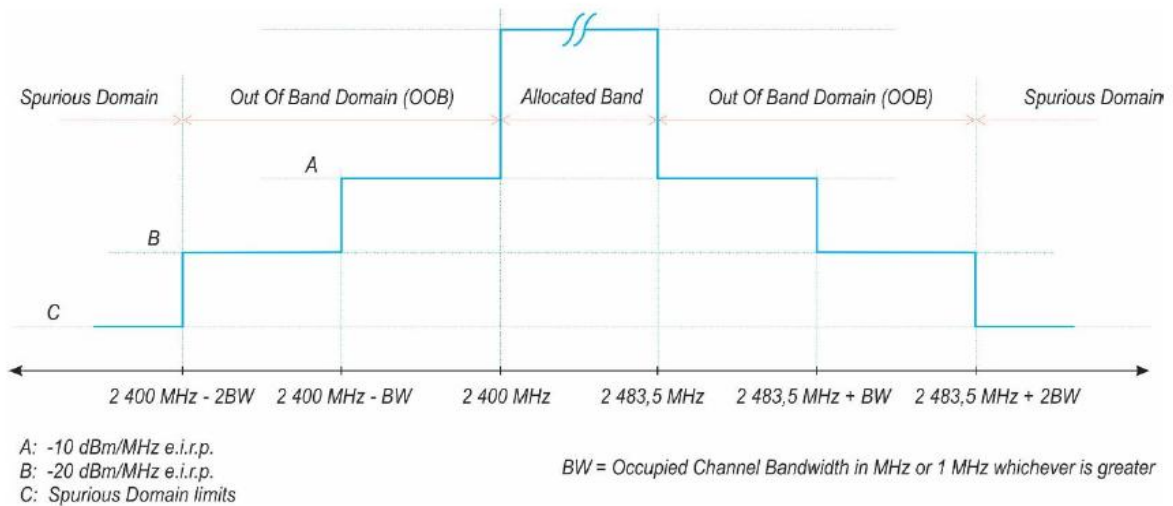

Figure 3: Transmit mask

9.3 Test Procedure

Refer to ETSI EN 300 328 V2.2.0 Clause 5.4.8.

Connect the UUT to the spectrum analyzer and use the following settings:



RBW/VBW	1MHz/3MHz
Span	0Hz
Filter mode	Channel filter
Sweep mode	Continuous
Sweep Points	5000
Detector	RMS
Trace mode	Clear/Write
Trigger Mode	Video trigger

9.4 Test Result

Test Mode	Test Condition	Lower Band Edge		Higher Band Edge	
		Segment A (dBm/MHz)	Segment B (dBm/MHz)	Segment A (dBm/MHz)	Segment B (dBm/MHz)
802.11b	Normal	-49.22	-53.59	-49.70	-49.22
802.11g	Normal	-47.70	-51.52	-49.76	-49.71
802.11n HT20	Normal	-48.32	-50.78	-48.31	-47.58
802.11n HT40	Normal	-49.70	-51.07	-51.25	-48.91
Limit		-10	-20	-10	-20
Conclusion		PASS			
Remark: (1)All modulations of EUT have been tested, but only show the test data of the worst case in this report.					
(2): Both Antenna 1 and Antenna 2 have been tested, and only the worst test result of Antenna 1 low channel is shown in the report.					



802.11 b CH Low (Normal Temp, Normal Voltage)

Channel	Antenna	Frequency	Level	Limit
CH Low-2412	Antenna 1	2399.5	-30.41	-10
CH Low-2412	Antenna 1	2398.5	-30.54	-10
CH Low-2412	Antenna 1	2397.5	-30.60	-10
CH Low-2412	Antenna 1	2396.5	-34.11	-10
CH Low-2412	Antenna 1	2395.5	-42.35	-10
CH Low-2412	Antenna 1	2394.5	-47.11	-10
CH Low-2412	Antenna 1	2393.5	-51.20	-10
CH Low-2412	Antenna 1	2392.5	-51.76	-10
CH Low-2412	Antenna 1	2391.5	-53.49	-10
CH Low-2412	Antenna 1	2390.5	-53.37	-10
CH Low-2412	Antenna 1	2389.5	-55.35	-10
CH Low-2412	Antenna 1	2388.5	-56.09	-10
CH Low-2412	Antenna 1	2387.5	-55.29	-10
CH Low-2412	Antenna 1	2386.462	-54.47	-20
CH Low-2412	Antenna 1	2385.462	-54.25	-20
CH Low-2412	Antenna 1	2384.462	-56.09	-20
CH Low-2412	Antenna 1	2383.462	-56.28	-20
CH Low-2412	Antenna 1	2382.462	-57.62	-20
CH Low-2412	Antenna 1	2381.462	-56.73	-20
CH Low-2412	Antenna 1	2380.462	-57.23	-20
CH Low-2412	Antenna 1	2379.462	-57.02	-20
CH Low-2412	Antenna 1	2378.462	-56.67	-20
CH Low-2412	Antenna 1	2377.462	-56.79	-20
CH Low-2412	Antenna 1	2376.462	-58.08	-20
CH Low-2412	Antenna 1	2375.462	-58.32	-20
CH Low-2412	Antenna 1	2374.462	-30.41	-20

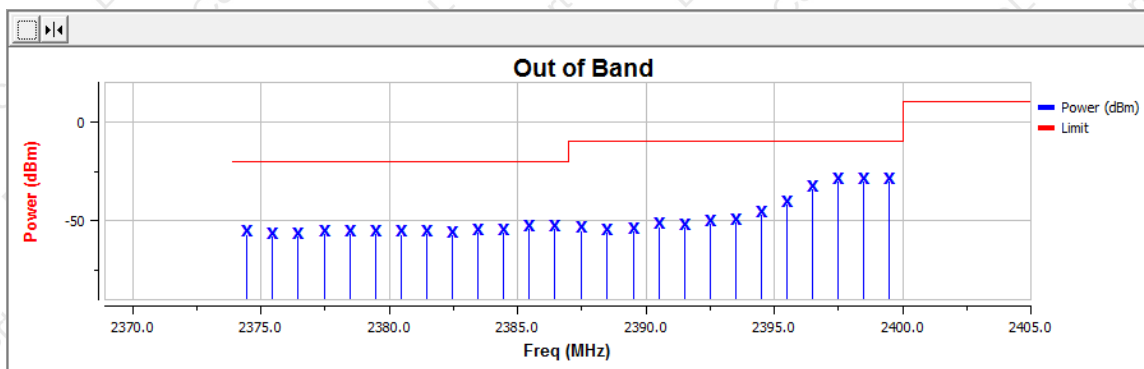



802.11 b CH High (Normal Temp, Normal Voltage)

Channel	Antenna	Frequency	Level	Limit
CH High-2472	Antenna 1	2496.223	-50.87	-10
CH High-2472	Antenna 1	2495.223	-51.83	-10
CH High-2472	Antenna 1	2494.223	-53.64	-10
CH High-2472	Antenna 1	2493.223	-48.04	-10
CH High-2472	Antenna 1	2492.223	-49.53	-10
CH High-2472	Antenna 1	2491.223	-48.14	-10
CH High-2472	Antenna 1	2490.223	-48.14	-10
CH High-2472	Antenna 1	2489.223	-50.96	-10
CH High-2472	Antenna 1	2488.223	-40.84	-10
CH High-2472	Antenna 1	2487.223	-33.83	-10
CH High-2472	Antenna 1	2486.223	-31.63	-10
CH High-2472	Antenna 1	2485.223	-30.78	-10
CH High-2472	Antenna 1	2484.223	-31.10	-10
CH High-2472	Antenna 1	2509.446	-57.25	-20
CH High-2472	Antenna 1	2508.446	-57.53	-20
CH High-2472	Antenna 1	2507.446	-56.85	-20
CH High-2472	Antenna 1	2506.446	-56.55	-20
CH High-2472	Antenna 1	2505.446	-57.42	-20
CH High-2472	Antenna 1	2504.446	-58.28	-20
CH High-2472	Antenna 1	2503.446	-57.87	-20
CH High-2472	Antenna 1	2502.446	-57.23	-20
CH High-2472	Antenna 1	2501.446	-56.90	-20
CH High-2472	Antenna 1	2500.446	-57.92	-20
CH High-2472	Antenna 1	2499.446	-56.51	-20
CH High-2472	Antenna 1	2498.446	-51.52	-20
CH High-2472	Antenna 1	2497.446	-49.17	-20

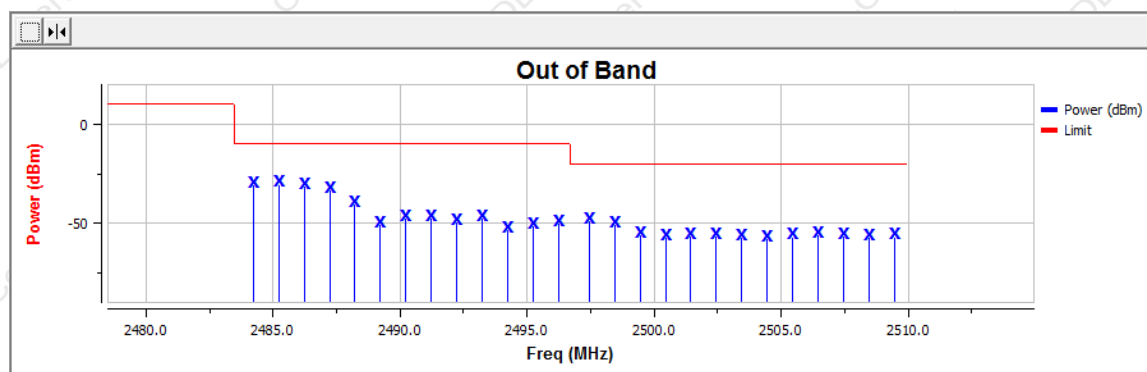



802.11 g CH Low (Normal Temp, Normal Voltage)

Channel	Antenna	Frequency	Level	Limit
CH Low-2412	Antenna 1	2399.5	-35.97	-10
CH Low-2412	Antenna 1	2398.5	-36.53	-10
CH Low-2412	Antenna 1	2397.5	-37.42	-10
CH Low-2412	Antenna 1	2396.5	-38.32	-10
CH Low-2412	Antenna 1	2395.5	-39.19	-10
CH Low-2412	Antenna 1	2394.5	-40.22	-10
CH Low-2412	Antenna 1	2393.5	-41.45	-10
CH Low-2412	Antenna 1	2392.5	-42.63	-10
CH Low-2412	Antenna 1	2391.5	-43.98	-10
CH Low-2412	Antenna 1	2390.5	-45.33	-10
CH Low-2412	Antenna 1	2389.5	-46.63	-10
CH Low-2412	Antenna 1	2388.5	-47.82	-10
CH Low-2412	Antenna 1	2387.5	-48.53	-10
CH Low-2412	Antenna 1	2386.5	-48.99	-10
CH Low-2412	Antenna 1	2385.5	-49.56	-10
CH Low-2412	Antenna 1	2384.5	-50.06	-10
CH Low-2412	Antenna 1	2383.152	-50.74	-20
CH Low-2412	Antenna 1	2382.152	-50.97	-20
CH Low-2412	Antenna 1	2381.152	-51.37	-20
CH Low-2412	Antenna 1	2380.152	-51.88	-20
CH Low-2412	Antenna 1	2379.152	-52.35	-20
CH Low-2412	Antenna 1	2377.152	-52.87	-20
CH Low-2412	Antenna 1	2376.152	-53.20	-20
CH Low-2412	Antenna 1	2374.152	-53.70	-20
CH Low-2412	Antenna 1	2373.152	-53.96	-20
CH Low-2412	Antenna 1	2371.152	-54.41	-20
CH Low-2412	Antenna 1	2369.152	-54.77	-20
CH Low-2412	Antenna 1	2368.152	-54.90	-20

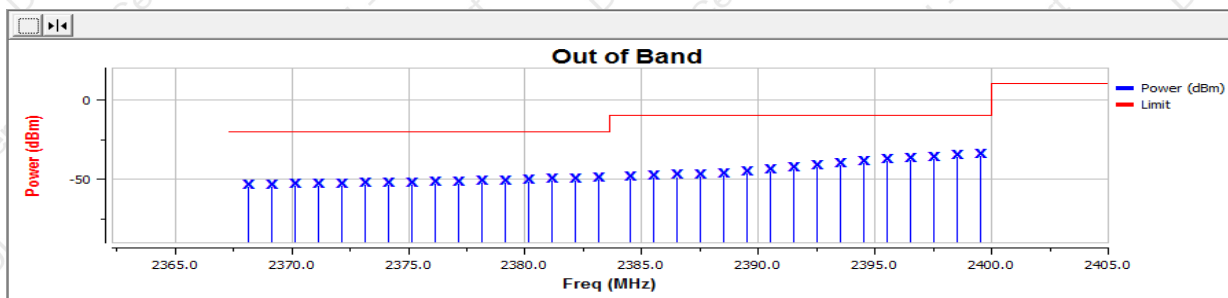



802.11 g CH High (Normal Temp, Normal Voltage)

Channel	Antenna	Frequency	Level	Limit
CH High-2472	Antenna 1	2499.356	-47.36	-10
CH High-2472	Antenna 1	2498.356	-46.74	-10
CH High-2472	Antenna 1	2497.356	-45.73	-10
CH High-2472	Antenna 1	2496.356	-45.26	-10
CH High-2472	Antenna 1	2495.356	-44.26	-10
CH High-2472	Antenna 1	2494.356	-43.10	-10
CH High-2472	Antenna 1	2493.356	-42.10	-10
CH High-2472	Antenna 1	2492.356	-40.99	-10
CH High-2472	Antenna 1	2491.356	-39.95	-10
CH High-2472	Antenna 1	2488.356	-37.06	-10
CH High-2472	Antenna 1	2487.356	-36.03	-10
CH High-2472	Antenna 1	2485.356	-34.36	-10
CH High-2472	Antenna 1	2484.356	-33.84	-10
CH High-2472	Antenna 1	2515.712	-55.29	-20
CH High-2472	Antenna 1	2514.712	-55.03	-20
CH High-2472	Antenna 1	2513.712	-54.81	-20
CH High-2472	Antenna 1	2512.712	-54.42	-20
CH High-2472	Antenna 1	2511.712	-54.14	-20
CH High-2472	Antenna 1	2510.712	-53.76	-20
CH High-2472	Antenna 1	2509.712	-53.44	-20
CH High-2472	Antenna 1	2508.712	-52.98	-20
CH High-2472	Antenna 1	2505.712	-51.61	-20
CH High-2472	Antenna 1	2504.712	-51.02	-20
CH High-2472	Antenna 1	2503.712	-50.46	-20
CH High-2472	Antenna 1	2502.712	-49.72	-20
CH High-2472	Antenna 1	2501.712	-49.15	-20
CH High-2472	Antenna 1	2500.712	-48.43	-20

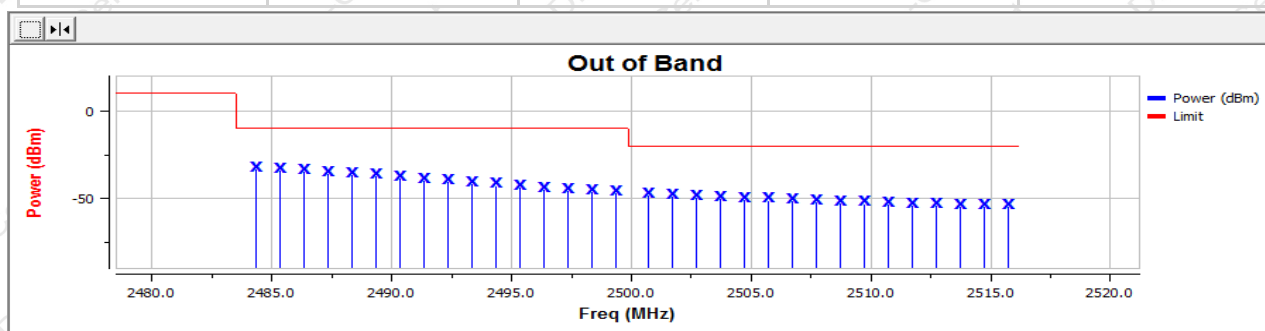



802.11 n20 CH Low (Normal Temp, Normal Voltage)

Channel	Antenna	Frequency	Level	Limit
CH Low-2412	Antenna 1	2399.5	-35.60	-10
CH Low-2412	Antenna 1	2398.5	-36.10	-10
CH Low-2412	Antenna 1	2397.5	-36.83	-10
CH Low-2412	Antenna 1	2396.5	-37.56	-10
CH Low-2412	Antenna 1	2395.5	-38.39	-10
CH Low-2412	Antenna 1	2394.5	-39.40	-10
CH Low-2412	Antenna 1	2391.5	-42.54	-10
CH Low-2412	Antenna 1	2390.5	-43.72	-10
CH Low-2412	Antenna 1	2389.5	-44.96	-10
CH Low-2412	Antenna 1	2388.5	-46.14	-10
CH Low-2412	Antenna 1	2387.5	-47.25	-10
CH Low-2412	Antenna 1	2386.5	-48.21	-10
CH Low-2412	Antenna 1	2385.5	-48.92	-10
CH Low-2412	Antenna 1	2384.5	-49.25	-10
CH Low-2412	Antenna 1	2383.5	-49.75	-10
CH Low-2412	Antenna 1	2381.948	-50.49	-20
CH Low-2412	Antenna 1	2380.948	-50.99	-20
CH Low-2412	Antenna 1	2379.948	-51.40	-20
CH Low-2412	Antenna 1	2378.948	-51.88	-20
CH Low-2412	Antenna 1	2377.948	-52.30	-20
CH Low-2412	Antenna 1	2376.948	-52.61	-20
CH Low-2412	Antenna 1	2375.948	-53.00	-20
CH Low-2412	Antenna 1	2374.948	-53.40	-20
CH Low-2412	Antenna 1	2371.948	-54.21	-20
CH Low-2412	Antenna 1	2370.948	-54.40	-20
CH Low-2412	Antenna 1	2367.948	-55.07	-20
CH Low-2412	Antenna 1	2366.948	-55.17	-20
CH Low-2412	Antenna 1	2365.948	-55.38	-20

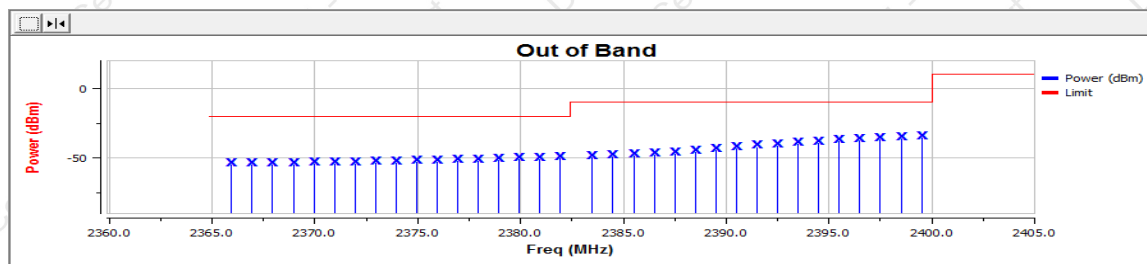



802.11 n20 CH High (Normal Temp, Normal Voltage)

Channel	Antenna	Frequency	Level	Limit
CH High-2472	Antenna 1	2500.548	-47.12	-10
CH High-2472	Antenna 1	2499.548	-46.43	-10
CH High-2472	Antenna 1	2498.548	-45.81	-10
CH High-2472	Antenna 1	2497.548	-44.94	-10
CH High-2472	Antenna 1	2496.548	-44.11	-10
CH High-2472	Antenna 1	2495.548	-43.04	-10
CH High-2472	Antenna 1	2494.548	-41.87	-10
CH High-2472	Antenna 1	2493.548	-40.94	-10
CH High-2472	Antenna 1	2492.548	-40.01	-10
CH High-2472	Antenna 1	2491.548	-39.09	-10
CH High-2472	Antenna 1	2490.548	-38.09	-10
CH High-2472	Antenna 1	2489.548	-37.23	-10
CH High-2472	Antenna 1	2488.548	-36.52	-10
CH High-2472	Antenna 1	2486.548	-34.93	-10
CH High-2472	Antenna 1	2485.548	-34.03	-10
CH High-2472	Antenna 1	2484.548	-33.62	-10
CH High-2472	Antenna 1	2483.548	-31.20	-10
CH High-2472	Antenna 1	2518.096	-55.54	-20
CH High-2472	Antenna 1	2516.096	-55.02	-20
CH High-2472	Antenna 1	2515.096	-54.69	-20
CH High-2472	Antenna 1	2510.096	-52.98	-20
CH High-2472	Antenna 1	2509.096	-52.35	-20
CH High-2472	Antenna 1	2508.096	-52.04	-20
CH High-2472	Antenna 1	2506.096	-50.96	-20
CH High-2472	Antenna 1	2503.096	-49.15	-20
CH High-2472	Antenna 1	2502.096	-48.26	-20
CH High-2472	Antenna 1	2501.096	-47.60	-20

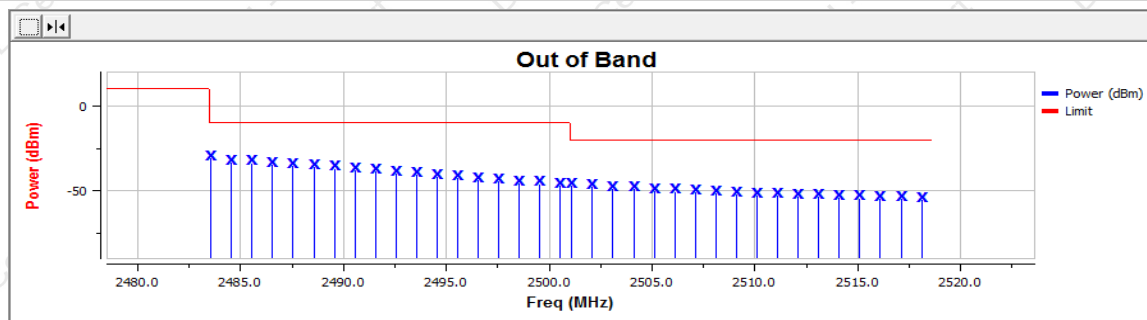

**802.11 n40 CH Low (Normal Temp, Normal Voltage)**

Channel	Antenna	Frequency	Level	Limit
CH Low-2422	Antenna 1	2399.5	-40.94	-10
CH Low-2422	Antenna 1	2398.5	-41.02	-10
CH Low-2422	Antenna 1	2397.5	-41.26	-10
CH Low-2422	Antenna 1	2396.5	-41.21	-10
CH Low-2422	Antenna 1	2395.5	-41.24	-10
CH Low-2422	Antenna 1	2394.5	-41.24	-10
CH Low-2422	Antenna 1	2393.5	-41.51	-10
CH Low-2422	Antenna 1	2392.5	-41.74	-10
CH Low-2422	Antenna 1	2391.5	-41.99	-10
CH Low-2422	Antenna 1	2390.5	-42.11	-10
CH Low-2422	Antenna 1	2389.5	-42.22	-10
CH Low-2422	Antenna 1	2388.5	-42.53	-10
CH Low-2422	Antenna 1	2387.5	-42.97	-10
CH Low-2422	Antenna 1	2386.5	-43.29	-10
CH Low-2422	Antenna 1	2385.5	-43.62	-10
CH Low-2422	Antenna 1	2384.5	-43.78	-10
CH Low-2422	Antenna 1	2383.5	-44.70	-10
CH Low-2422	Antenna 1	2382.5	-45.22	-10
CH Low-2422	Antenna 1	2381.5	-45.60	-10
CH Low-2422	Antenna 1	2380.5	-46.13	-10
CH Low-2422	Antenna 1	2379.5	-46.45	-10
CH Low-2422	Antenna 1	2378.5	-47.07	-10
CH Low-2422	Antenna 1	2377.5	-47.59	-10
CH Low-2422	Antenna 1	2376.5	-48.12	-10
CH Low-2422	Antenna 1	2375.5	-48.60	-10
CH Low-2422	Antenna 1	2374.5	-49.00	-10
CH Low-2422	Antenna 1	2373.5	-49.61	-10
CH Low-2422	Antenna 1	2372.5	-50.05	-10
CH Low-2422	Antenna 1	2371.5	-50.58	-10
CH Low-2422	Antenna 1	2370.5	-50.90	-10
CH Low-2422	Antenna 1	2369.5	-51.20	-10
CH Low-2422	Antenna 1	2368.5	-51.60	-10
CH Low-2422	Antenna 1	2367.5	-52.08	-10
CH Low-2422	Antenna 1	2366.5	-52.38	-10
CH Low-2422	Antenna 1	2365.5	-52.61	-10



CH Low-2422	Antenna 1	2363.602	-53.52	-20
CH Low-2422	Antenna 1	2362.602	-54.04	-20
CH Low-2422	Antenna 1	2361.602	-54.36	-20
CH Low-2422	Antenna 1	2360.602	-54.63	-20
CH Low-2422	Antenna 1	2359.602	-54.89	-20
CH Low-2422	Antenna 1	2358.602	-55.29	-20
CH Low-2422	Antenna 1	2357.602	-55.57	-20
CH Low-2422	Antenna 1	2356.602	-55.86	-20
CH Low-2422	Antenna 1	2355.602	-56.22	-20
CH Low-2422	Antenna 1	2354.602	-56.51	-20
CH Low-2422	Antenna 1	2353.602	-56.93	-20
CH Low-2422	Antenna 1	2352.602	-57.28	-20
CH Low-2422	Antenna 1	2351.602	-57.81	-20
CH Low-2422	Antenna 1	2350.602	-58.06	-20
CH Low-2422	Antenna 1	2349.602	-58.23	-20
CH Low-2422	Antenna 1	2348.602	-58.68	-20
CH Low-2422	Antenna 1	2345.602	-59.62	-20
CH Low-2422	Antenna 1	2344.602	-59.86	-20
CH Low-2422	Antenna 1	2338.602	-61.72	-20
CH Low-2422	Antenna 1	2337.602	-61.97	-20
CH Low-2422	Antenna 1	2335.602	-62.59	-20
CH Low-2422	Antenna 1	2334.602	-62.80	-20
CH Low-2422	Antenna 1	2333.602	-63.12	-20
CH Low-2422	Antenna 1	2332.602	-63.37	-20
CH Low-2422	Antenna 1	2331.602	-63.61	-20
CH Low-2422	Antenna 1	2330.602	-63.88	-20
CH Low-2422	Antenna 1	2329.602	-64.14	-20

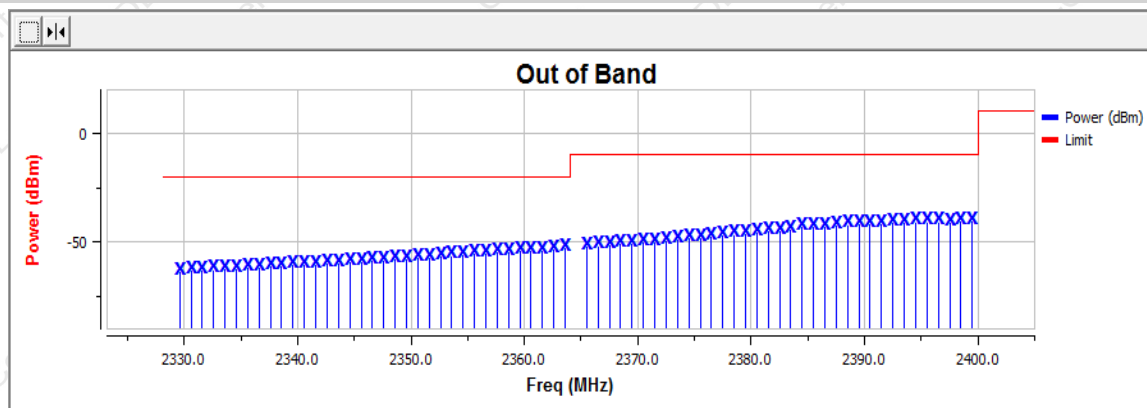

**802.11 n40 CH High (Normal Temp, Normal Voltage)**

Channel	Antenna	Frequency	Level	Limit
CH High-2462	Antenna 1	2518.952	-51.49	-10
CH High-2462	Antenna 1	2517.952	-51.34	-10
CH High-2462	Antenna 1	2516.952	-50.86	-10
CH High-2462	Antenna 1	2515.952	-50.64	-10
CH High-2462	Antenna 1	2514.952	-50.48	-10
CH High-2462	Antenna 1	2513.952	-50.15	-10
CH High-2462	Antenna 1	2512.952	-49.97	-10
CH High-2462	Antenna 1	2511.952	-49.75	-10
CH High-2462	Antenna 1	2510.952	-49.29	-10
CH High-2462	Antenna 1	2509.952	-48.97	-10
CH High-2462	Antenna 1	2508.952	-48.77	-10
CH High-2462	Antenna 1	2507.952	-48.61	-10
CH High-2462	Antenna 1	2506.952	-48.37	-10
CH High-2462	Antenna 1	2505.952	-48.24	-10
CH High-2462	Antenna 1	2504.952	-47.94	-10
CH High-2462	Antenna 1	2503.952	-47.72	-10
CH High-2462	Antenna 1	2502.952	-47.40	-10
CH High-2462	Antenna 1	2501.952	-47.12	-10
CH High-2462	Antenna 1	2496.952	-45.36	-10
CH High-2462	Antenna 1	2495.952	-44.97	-10
CH High-2462	Antenna 1	2494.952	-44.65	-10
CH High-2462	Antenna 1	2493.952	-44.51	-10
CH High-2462	Antenna 1	2492.952	-44.16	-10
CH High-2462	Antenna 1	2491.952	-44.37	-10
CH High-2462	Antenna 1	2490.952	-44.13	-10
CH High-2462	Antenna 1	2489.952	-43.87	-10
CH High-2462	Antenna 1	2488.952	-43.89	-10
CH High-2462	Antenna 1	2487.952	-43.66	-10
CH High-2462	Antenna 1	2486.952	-43.51	-10
CH High-2462	Antenna 1	2485.952	-43.04	-10
CH High-2462	Antenna 1	2484.952	-43.13	-10
CH High-2462	Antenna 1	2483.952	-42.43	-10
CH High-2462	Antenna 1	2554.904	-61.96	-20
CH High-2462	Antenna 1	2553.904	-61.74	-20
CH High-2462	Antenna 1	2552.904	-61.58	-20



CH High-2462	Antenna 1	2551.904	-61.23	-20
CH High-2462	Antenna 1	2550.904	-61.13	-20
CH High-2462	Antenna 1	2549.904	-61.00	-20
CH High-2462	Antenna 1	2548.904	-60.73	-20
CH High-2462	Antenna 1	2545.904	-60.16	-20
CH High-2462	Antenna 1	2544.904	-59.86	-20
CH High-2462	Antenna 1	2543.904	-59.65	-20
CH High-2462	Antenna 1	2542.904	-59.46	-20
CH High-2462	Antenna 1	2541.904	-59.21	-20
CH High-2462	Antenna 1	2540.904	-58.90	-20
CH High-2462	Antenna 1	2537.904	-58.15	-20
CH High-2462	Antenna 1	2536.904	-57.79	-20
CH High-2462	Antenna 1	2535.904	-57.33	-20
CH High-2462	Antenna 1	2534.904	-57.07	-20
CH High-2462	Antenna 1	2533.904	-56.75	-20
CH High-2462	Antenna 1	2531.904	-56.17	-20
CH High-2462	Antenna 1	2530.904	-55.84	-20
CH High-2462	Antenna 1	2529.904	-55.54	-20
CH High-2462	Antenna 1	2528.904	-55.12	-20
CH High-2462	Antenna 1	2525.904	-53.96	-20
CH High-2462	Antenna 1	2524.904	-53.62	-20
CH High-2462	Antenna 1	2523.904	-53.22	-20
CH High-2462	Antenna 1	2522.904	-52.93	-20
CH High-2462	Antenna 1	2521.904	-52.47	-20
CH High-2462	Antenna 1	2520.904	-52.26	-20
CH High-2462	Antenna 1	2519.904	-51.85	-20

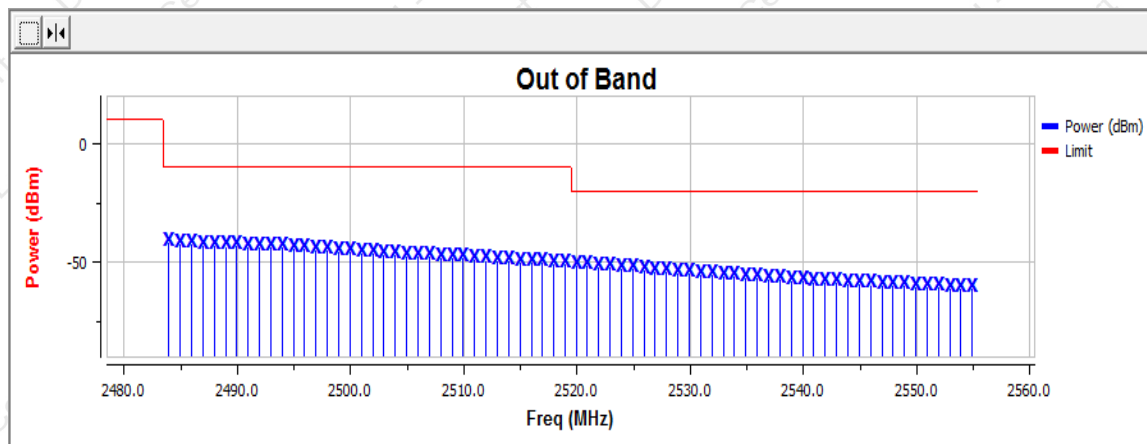

10. TRANSMITTER UNWANTED EMISSIONS IN THE SPURIOUS DOMAIN

10.1 Block Diagram of Test Setup

Below 1GHz

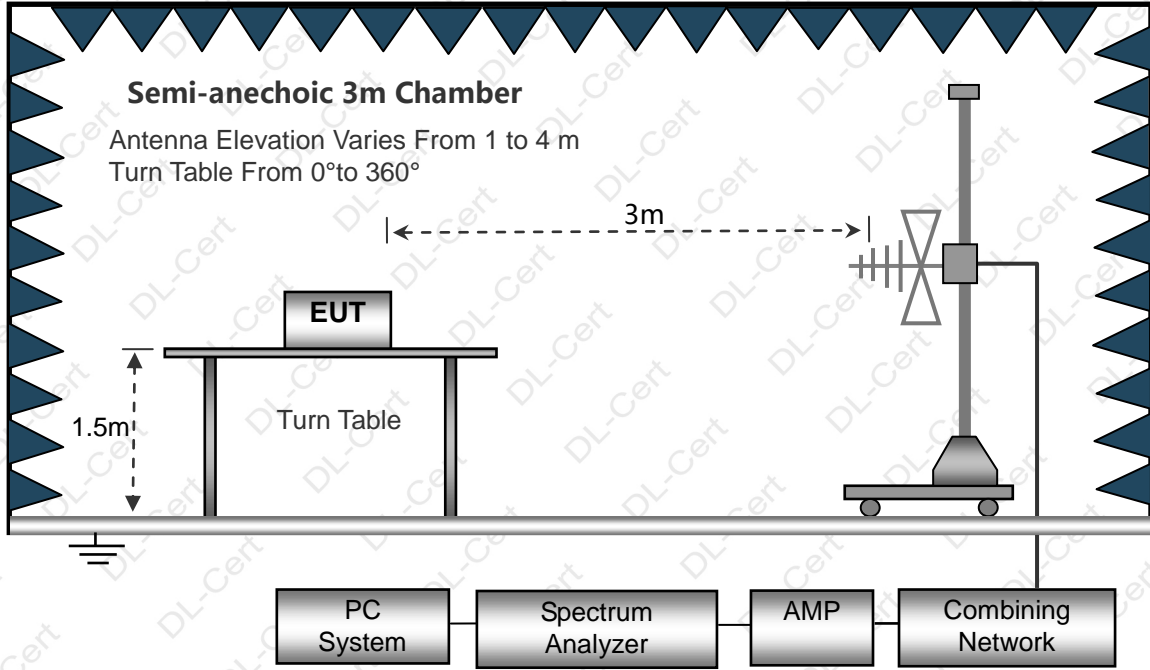

Above 1GHz

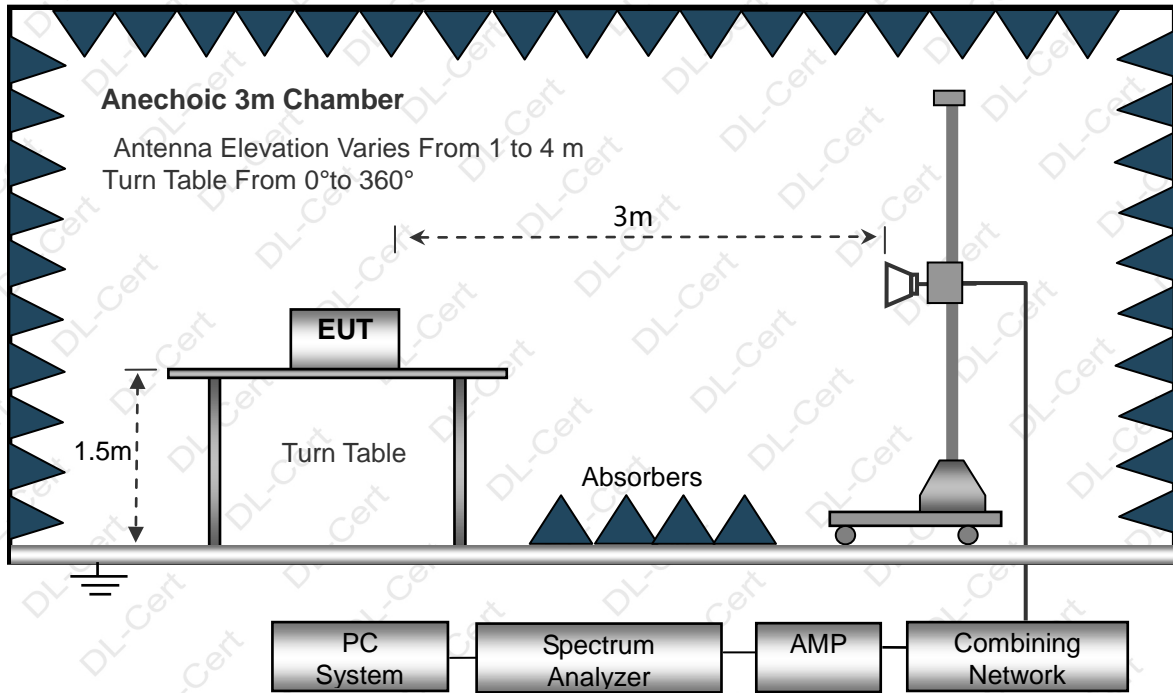



10.2 Limit

The transmitter unwanted emissions in the spurious domain shall not exceed the values given in table 12.

Table 12: Transmitter limits for spurious emissions

Frequency range	Maximum power	Bandwidth
30 MHz to 47 MHz	-36 dBm	100 kHz
47 MHz to 74 MHz	-54 dBm	100 kHz
74 MHz to 87,5 MHz	-36 dBm	100 kHz
87,5 MHz to 118 MHz	-54 dBm	100 kHz
118 MHz to 174 MHz	-36 dBm	100 kHz
174 MHz to 230 MHz	-54 dBm	100 kHz
230 MHz to 470 MHz	-36 dBm	100 kHz
470 MHz to 694 MHz	-54 dBm	100 kHz
694 MHz to 1 GHz	-36 dBm	100 kHz
1 GHz to 12,75 GHz	-30 dBm	1 MHz

10.3 Test Procedure

Refer to ETSI EN 300 328 V2.2.0 Clause 5.4.9.

10.4 Test Result

Below 1GHz

Spurious Emission Test Data					
Frequency (MHz)	Polarization	Level (dBm)	Limit (dBm)	Marging (dB)	Result
39.60	Vertical	-67.02	-36	-31.02	Pass
161.00	Vertical	-67.53	-36	-31.53	Pass
189.85	Vertical	-66.56	-54	-12.56	Pass
447.65	Vertical	-65.86	-36	-29.86	Pass
564.90	Vertical	-66.16	-54	-12.16	Pass
793.50	Vertical	-65.44	-36	-29.44	Pass
42.60	Horizontal	-67.73	-36	-31.73	Pass
107.80	Horizontal	-67.29	-54	-13.29	Pass
208.55	Horizontal	-66.83	-54	-12.83	Pass
369.30	Horizontal	-65.65	-36	-29.65	Pass
645.30	Horizontal	-66.37	-54	-12.37	Pass
897.65	Horizontal	-65.09	-36	-29.09	Pass

Note1: Both Antenna 1 and Antenna 2 have been tested, and only the worst test result of Antenna 1 low channel is shown in the report.



Above 1GHz

Spurious Emission Test Data						
Mode	Frequency (MHz)	Polarization	Level (dBm)	Limit (dBm)	Margin (dB)	Result
802.11b Low Channel	4824	Vertical	-42.48	-30.00	-12.48	Pass
	7236	Vertical	-44.93	-30.00	-14.93	Pass
	9648	Vertical	-47.87	-30.00	-17.87	Pass
	4824	Horizontal	-42.65	-30.00	-12.65	Pass
	7236	Horizontal	-46.20	-30.00	-16.20	Pass
	9648	Horizontal	-48.55	-30.00	-18.55	Pass
802.11b Middle Channel	4884	Vertical	-42.35	-30.00	-12.35	Pass
	7326	Vertical	-44.35	-30.00	-14.35	Pass
	9768	Vertical	-49.52	-30.00	-19.52	Pass
	4884	Horizontal	-41.47	-30.00	-11.47	Pass
	7326	Horizontal	-45.64	-30.00	-15.64	Pass
	9768	Horizontal	-48.60	-30.00	-18.60	Pass
802.11b High Channel	4944	Vertical	-41.87	-30.00	-11.87	Pass
	7416	Vertical	-43.80	-30.00	-13.80	Pass
	9888	Vertical	-47.29	-30.00	-17.29	Pass
	4944	Horizontal	-41.85	-30.00	-11.85	Pass
	7416	Horizontal	-45.03	-30.00	-15.03	Pass
	9888	Horizontal	-48.73	-30.00	-18.73	Pass
802.11g Low Channel	4824	Vertical	-41.97	-30.00	-11.97	Pass
	7236	Vertical	-44.94	-30.00	-14.94	Pass
	9648	Vertical	-47.83	-30.00	-17.83	Pass
	4824	Horizontal	-42.63	-30.00	-12.63	Pass
	7236	Horizontal	-46.26	-30.00	-16.26	Pass
	9648	Horizontal	-48.52	-30.00	-18.52	Pass
802.11g Middle Channel	4884	Vertical	-42.93	-30.00	-12.93	Pass
	7326	Vertical	-46.73	-30.00	-16.73	Pass
	9768	Vertical	-49.69	-30.00	-19.69	Pass
	4884	Horizontal	-43.03	-30.00	-13.03	Pass
	7326	Horizontal	-45.81	-30.00	-15.81	Pass
	9768	Horizontal	-50.50	-30.00	-20.50	Pass
802.11g High Channel	4944	Vertical	-43.80	-30.00	-13.80	Pass
	7416	Vertical	-45.91	-30.00	-15.91	Pass
	9888	Vertical	-50.48	-30.00	-20.48	Pass
	4944	Horizontal	-42.62	-30.00	-12.62	Pass
	7416	Horizontal	-46.71	-30.00	-16.71	Pass
	9888	Horizontal	-47.39	-30.00	-17.39	Pass



Spurious Emission Test Data						
Mode	Frequency (MHz)	Polarization	Level (dBm)	Limit (dBm)	Margin (dB)	Result
802.11n HT20 Low Channel	4824	Vertical	-42.54	-30.00	-12.54	Pass
	7236	Vertical	-45.05	-30.00	-15.05	Pass
	9648	Vertical	-48.08	-30.00	-18.08	Pass
	4824	Horizontal	-42.73	-30.00	-12.73	Pass
	7236	Horizontal	-46.42	-30.00	-16.42	Pass
	9648	Horizontal	-48.69	-30.00	-18.69	Pass
802.11n HT20 Middle Channel	4884	Vertical	-42.45	-30.00	-12.45	Pass
	7326	Vertical	-44.57	-30.00	-14.57	Pass
	9768	Vertical	-49.66	-30.00	-19.66	Pass
	4884	Horizontal	-41.69	-30.00	-11.69	Pass
	7326	Horizontal	-45.77	-30.00	-15.77	Pass
	9768	Horizontal	-49.25	-30.00	-19.25	Pass
802.11n HT20 High Channel	4944	Vertical	-42.05	-30.00	-12.05	Pass
	7416	Vertical	-43.89	-30.00	-13.89	Pass
	9888	Vertical	-47.42	-30.00	-17.42	Pass
	4944	Horizontal	-41.98	-30.00	-11.98	Pass
	7416	Horizontal	-45.15	-30.00	-15.15	Pass
	9888	Horizontal	-48.85	-30.00	-18.85	Pass
802.11n HT40 Low Channel	4844	Vertical	-42.46	-30.00	-12.46	Pass
	7266	Vertical	-45.28	-30.00	-15.28	Pass
	9688	Vertical	-48.09	-30.00	-18.09	Pass
	4844	Horizontal	-42.92	-30.00	-12.92	Pass
	7266	Horizontal	-46.53	-30.00	-16.53	Pass
	9688	Horizontal	-49.39	-30.00	-19.39	Pass
802.11n HT40 Middle Channel	4884	Vertical	-43.24	-30.00	-13.24	Pass
	7326	Vertical	-46.95	-30.00	-16.95	Pass
	9768	Vertical	-49.97	-30.00	-19.97	Pass
	4884	Horizontal	-43.22	-30.00	-13.22	Pass
	7326	Horizontal	-46.05	-30.00	-16.05	Pass
	9768	Horizontal	-50.84	-30.00	-20.84	Pass
802.11n HT40 High Channel	4924	Vertical	-44.41	-30.00	-14.41	Pass
	7386	Vertical	-46.21	-30.00	-16.21	Pass
	9848	Vertical	-50.73	-30.00	-20.73	Pass
	4924	Horizontal	-42.91	-30.00	-12.91	Pass
	7386	Horizontal	-47.36	-30.00	-17.36	Pass
	9848	Horizontal	-50.62	-30.00	-20.62	Pass

Note1: Both Antenna 1 and Antenna 2 have been tested, and only the worst test result of Antenna 1 low channel is shown in the report.

11. RECEIVER SPURIOUS EMISSIONS

11.1 Block Diagram of Test Setup

Below 1GHz

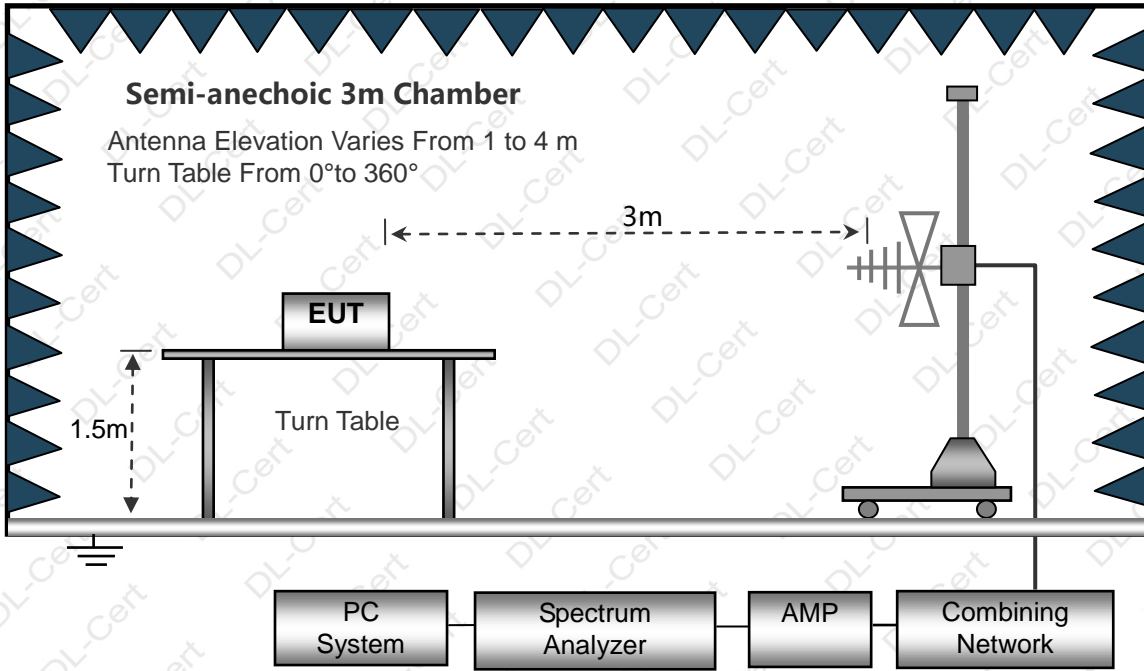

Above 1GHz

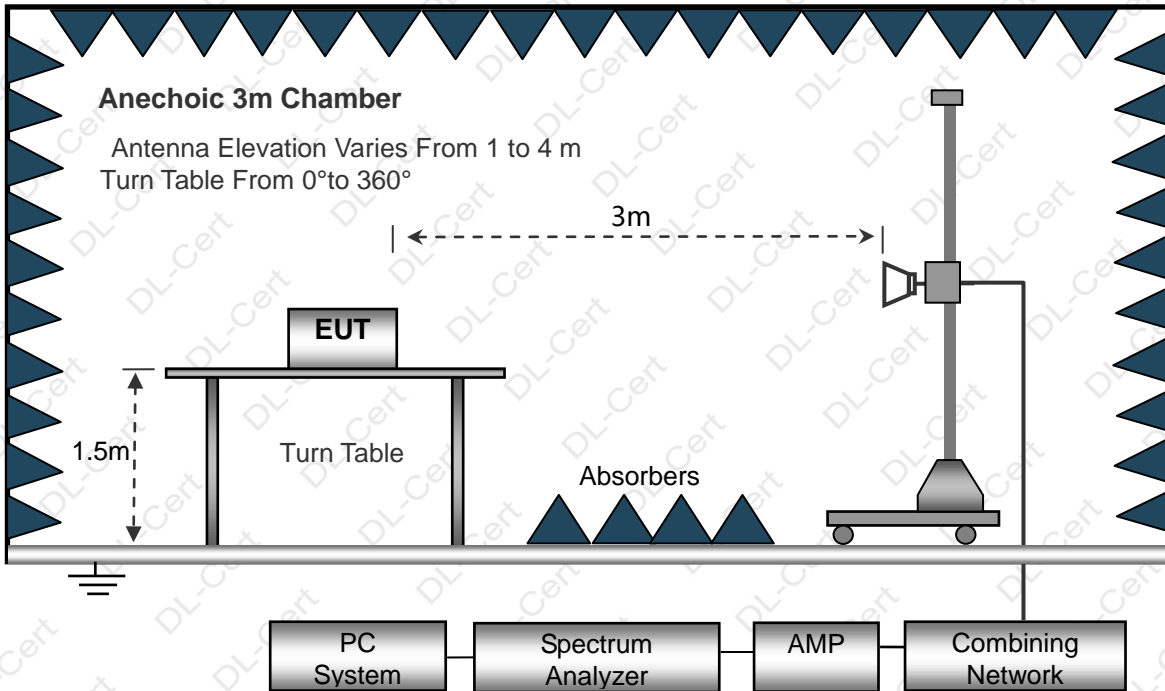



11.2 Limit

The spurious emissions of the receiver shall not exceed the values given in table 13.

Table 13: Spurious emission limits for receivers

Frequency range	Maximum power	Bandwidth
30 MHz to 1 GHz	-57 dBm	100 kHz
1 GHz to 12,75 GHz	-47 dBm	1 MHz

11.3 Test Procedure

Refer to ETSI EN 300 328 V2.2.0 Clause 5.4.9.

11.4 Test Result

Below 1GHz

Receiver spurious emissions Test Data					
Frequency (MHz)	Polarization	Level (dBm)	Limit (dBm)	Marging (dB)	Result
34.22	Vertical	-67.62	-57.00	-10.62	Pass
97.97	Vertical	-68.8	-57.00	-11.80	Pass
189.59	Vertical	-68.6	-57.00	-11.60	Pass
233.49	Vertical	-68.63	-57.00	-11.63	Pass
481.48	Vertical	-68.62	-57.00	-11.62	Pass
822.53	Vertical	-68.34	-57.00	-11.34	Pass
42.42	Horizontal	-68.94	-57.00	-11.94	Pass
122.49	Horizontal	-68.31	-57.00	-11.31	Pass
307.54	Horizontal	-68.54	-57.00	-11.54	Pass
481.49	Horizontal	-69.64	-57.00	-12.64	Pass
591.19	Horizontal	-70.28	-57.00	-13.28	Pass
899.86	Horizontal	-71.41	-57.00	-14.41	Pass

Note1: Both Antenna 1 and Antenna 2 have been tested, and only the worst test result of Antenna 1 low channel is shown in the report.



Above 1GHz

Receiver spurious emissions Test Data						
Mode	Frequency (MHz)	Polarization	Level (dBm)	Limit (dBm)	Margin (dB)	Result
802.11b Low Channel	4824	Vertical	-58.39	-47.00	-11.39	Pass
	7236	Vertical	-58.59	-47.00	-11.59	Pass
	9648	Vertical	-64.67	-47.00	-17.67	Pass
	4824	Horizontal	-57.60	-47.00	-10.60	Pass
	7236	Horizontal	-65.19	-47.00	-18.19	Pass
	9648	Horizontal	-64.53	-47.00	-17.53	Pass
802.11b Middle Channel	4884	Vertical	-62.86	-47.00	-15.86	Pass
	7326	Vertical	-62.94	-47.00	-15.94	Pass
	9768	Vertical	-57.57	-47.00	-10.57	Pass
	4884	Horizontal	-57.96	-47.00	-10.96	Pass
	7326	Horizontal	-64.18	-47.00	-17.18	Pass
	9768	Horizontal	-65.73	-47.00	-18.73	Pass
802.11b High Channel	4944	Vertical	-63.53	-47.00	-16.53	Pass
	7416	Vertical	-65.20	-47.00	-18.20	Pass
	9888	Vertical	-61.00	-47.00	-14.00	Pass
	4944	Horizontal	-60.45	-47.00	-13.45	Pass
	7416	Horizontal	-60.07	-47.00	-13.07	Pass
	9888	Horizontal	-62.55	-47.00	-15.55	Pass
802.11g Low Channel	4824	Vertical	-58.17	-47.00	-11.17	Pass
	7236	Vertical	-57.59	-47.00	-10.59	Pass
	9648	Vertical	-64.20	-47.00	-17.20	Pass
	4824	Horizontal	-60.97	-47.00	-13.97	Pass
	7236	Horizontal	-60.26	-47.00	-13.26	Pass
	9648	Horizontal	-59.96	-47.00	-12.96	Pass
802.11g Middle Channel	4884	Vertical	-65.18	-47.00	-18.18	Pass
	7326	Vertical	-63.22	-47.00	-16.22	Pass
	9768	Vertical	-57.94	-47.00	-10.94	Pass
	4884	Horizontal	-62.19	-47.00	-15.19	Pass
	7326	Horizontal	-58.27	-47.00	-11.27	Pass
	9768	Horizontal	-60.51	-47.00	-13.51	Pass
802.11g High Channel	4944	Vertical	-64.43	-47.00	-17.43	Pass
	7416	Vertical	-60.00	-47.00	-13.00	Pass
	9888	Vertical	-60.10	-47.00	-13.10	Pass
	4944	Horizontal	-63.22	-47.00	-16.22	Pass
	7416	Horizontal	-59.94	-47.00	-12.94	Pass
	9888	Horizontal	-59.55	-47.00	-12.55	Pass



Receiver spurious emissions Test Data						
Mode	Frequency (MHz)	Polarization	Level (dBm)	Limit (dBm)	Margin (dB)	Result
802.11n HT20 Low Channel	4824	Vertical	-60.61	-47.00	-13.61	Pass
	7236	Vertical	-57.76	-47.00	-10.76	Pass
	9648	Vertical	-57.76	-47.00	-10.76	Pass
	4824	Horizontal	-58.78	-47.00	-11.78	Pass
	7236	Horizontal	-59.57	-47.00	-12.57	Pass
	9648	Horizontal	-56.74	-47.00	-9.74	Pass
802.11n HT20 Middle Channel	4884	Vertical	-61.89	-47.00	-14.89	Pass
	7326	Vertical	-58.85	-47.00	-11.85	Pass
	9768	Vertical	-61.44	-47.00	-14.44	Pass
	4884	Horizontal	-61.68	-47.00	-14.68	Pass
	7326	Horizontal	-62.18	-47.00	-15.18	Pass
	9768	Horizontal	-62.85	-47.00	-15.85	Pass
802.11n HT20 High Channel	4944	Vertical	-58.15	-47.00	-11.15	Pass
	7416	Vertical	-59.52	-47.00	-12.52	Pass
	9888	Vertical	-58.49	-47.00	-11.49	Pass
	4944	Horizontal	-59.34	-47.00	-12.34	Pass
	7416	Horizontal	-60.07	-47.00	-13.07	Pass
	9888	Horizontal	-57.73	-47.00	-10.73	Pass
802.11n HT40 Low Channel	4844	Vertical	-60.70	-47.00	-13.70	Pass
	7266	Vertical	-60.60	-47.00	-13.60	Pass
	9688	Vertical	-57.65	-47.00	-10.65	Pass
	4844	Horizontal	-58.38	-47.00	-11.38	Pass
	7266	Horizontal	-60.74	-47.00	-13.74	Pass
	9688	Horizontal	-58.06	-47.00	-11.06	Pass
802.11n HT40 Middle Channel	4884	Vertical	-57.39	-47.00	-10.39	Pass
	7326	Vertical	-58.38	-47.00	-11.38	Pass
	9768	Vertical	-58.29	-47.00	-11.29	Pass
	4884	Horizontal	-62.73	-47.00	-15.73	Pass
	7326	Horizontal	-59.95	-47.00	-12.95	Pass
	9768	Horizontal	-63.69	-47.00	-16.69	Pass
802.11n HT40 High Channel	4924	Vertical	-59.23	-47.00	-12.23	Pass
	7386	Vertical	-64.06	-47.00	-17.06	Pass
	9848	Vertical	-61.03	-47.00	-14.03	Pass
	4924	Horizontal	-60.94	-47.00	-13.94	Pass
	7386	Horizontal	-59.83	-47.00	-12.83	Pass
	9848	Horizontal	-59.56	-47.00	-12.56	Pass

Note1: Both Antenna 1 and Antenna 2 have been tested, and only the worst test result of Antenna 1 low channel is shown in the report.

12. RECEIVER BLOCKING

12.1 Block Diagram of Test Setup

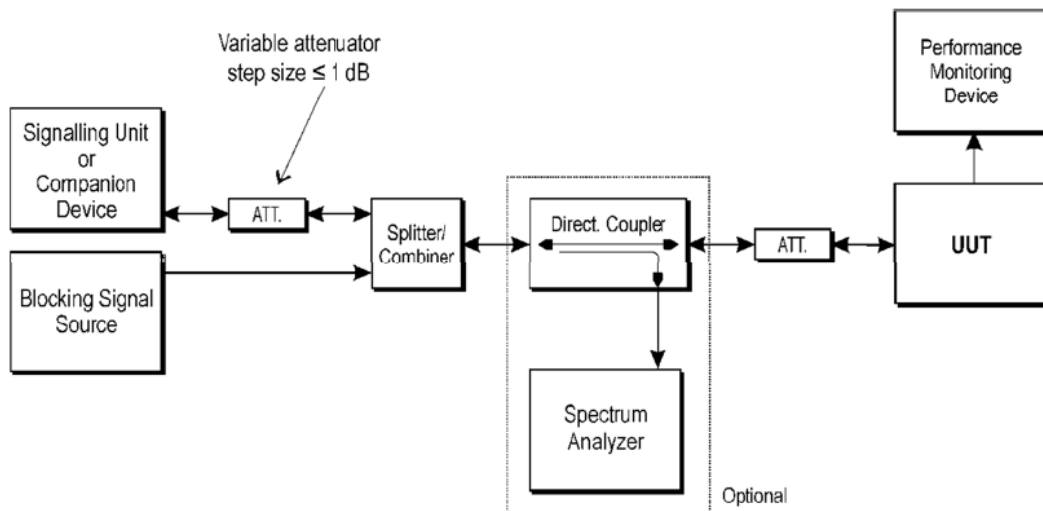

12.2 Limit

Table 14 contains the Receiver Blocking parameters for Receiver Category 1 equipment.

Table 14: Receiver Blocking parameters for Receiver Category 1 equipment

Wanted signal mean power from companion device (dBm) (see notes 1 and 4)	Blocking signal frequency (MHz)	Blocking signal power (dBm) (see note 4)	Type of blocking signal
$(-133 \text{ dBm} + 10 \times \log_{10}(\text{OCBW}))$ or -68 dBm whichever is less (see note 2)	2 380 2 504	-34	CW
$(-139 \text{ dBm} + 10 \times \log_{10}(\text{OCBW}))$ or -74 dBm whichever is less (see note 3)	2 300 2 330 2 360 2 524 2 584 2 674		
<p>NOTE 1: OCBW is in Hz.</p> <p>NOTE 2: In case of radiated measurements using a companion device and the level of the wanted signal from the companion device cannot be determined, a relative test may be performed using a wanted signal up to $P_{\min} + 26 \text{ dB}$ where P_{\min} is the minimum level of wanted signal required to meet the minimum performance criteria as defined in clause 4.3.1.12.3 in the absence of any blocking signal.</p> <p>NOTE 3: In case of radiated measurements using a companion device and the level of the wanted signal from the companion device cannot be determined, a relative test may be performed using a wanted signal up to $P_{\min} + 20 \text{ dB}$ where P_{\min} is the minimum level of wanted signal required to meet the minimum performance criteria as defined in clause 4.3.1.12.3 in the absence of any blocking signal.</p> <p>NOTE 4: The level specified is the level at the UUT receiver input assuming a 0 dBi antenna assembly gain. In case of conducted measurements, this level has to be corrected for the (in-band) antenna assembly gain (G). In case of radiated measurements, this level is equivalent to a power flux density (PFD) in front of the UUT antenna with the UUT being configured/positioned as recorded in clause 5.4.3.2.2.</p>			



Table 15 contains the Receiver Blocking parameters for Receiver Category 2 equipment.

Table 15: Receiver Blocking parameters receiver Category 2 equipment

Wanted signal mean power from companion device (dBm) (see notes 1 and 3)	Blocking signal frequency (MHz)	Blocking signal power (dBm) (see note 3)	Type of blocking signal
(-139 dBm + 10 × log ₁₀ (OCBW) + 10 dB) or (-74 dBm + 10 dB) whichever is less (see note 2)	2 380 2 504 2 300 2 584	-34	CW
NOTE 1: OCBW is in Hz. NOTE 2: In case of radiated measurements using a companion device and the level of the wanted signal from the companion device cannot be determined, a relative test may be performed using a wanted signal up to P _{min} + 26 dB where P _{min} is the minimum level of wanted signal required to meet the minimum performance criteria as defined in clause 4.3.1.12.3 in the absence of any blocking signal. NOTE 3: The level specified is the level at the UUT receiver input assuming a 0 dBi antenna assembly gain. In case of conducted measurements, this level has to be corrected for the (in-band) antenna assembly gain (G). In case of radiated measurements, this level is equivalent to a power flux density (PFD) in front of the UUT antenna with the UUT being configured/positioned as recorded in clause 5.4.3.2.2.			

Table 16 contains the Receiver Blocking parameters for Receiver Category 3 equipment.

Table 16: Receiver Blocking parameters receiver Category 3 equipment

Wanted signal mean power from companion device (dBm) (see notes 1 and 3)	Blocking signal frequency (MHz)	Blocking signal power (dBm) (see note 3)	Type of blocking signal
(-139 dBm + 10 × log ₁₀ (OCBW) + 20 dB) or (-74 dBm + 20 dB) whichever is less (see note 2)	2 380 2 504 2 300 2 584	-34	CW
NOTE 1: OCBW is in Hz. NOTE 2: In case of radiated measurements using a companion device and the level of the wanted signal from the companion device cannot be determined, a relative test may be performed using a wanted signal up to P _{min} + 30 dB where P _{min} is the minimum level of wanted signal required to meet the minimum performance criteria as defined in clause 4.3.1.12.3 in the absence of any blocking signal. NOTE 3: The level specified is the level at the UUT receiver input assuming a 0 dBi antenna assembly gain. In case of conducted measurements, this level has to be corrected for the (in-band) antenna assembly gain (G). In case of radiated measurements, this level is equivalent to a power flux density (PFD) in front of the UUT antenna with the UUT being configured/positioned as recorded in clause 5.4.3.2.2.			

12.3 Test Procedure

Refer to ETSI EN 300 328 V2.2.0 Clause 5.4.11.

12.4 Test Results

PASS

Observation Result: Refer to 5 that blocking signal is injected while interference signal is present. With the presence of the blocking signal, channel of the observation does not resume the link.



13. GEO-LOCATION CAPABILITY

13.1 Definition and Requirements

Geo-location capability is a feature of the equipment to determine its geographical location with the purpose to configure itself according to the regulatory requirements applicable at the geographical location where it operates.

The geo-location capability may be present in the equipment or in an external device (temporary) associated with the equipment operating at the same geographical location during the initial power up of the equipment. The geographical location may also be available in equipment already installed and operating at the same geographical location.

13.2 Test Results

This product doesn't support Geo-location.



14. EUT PHOTOGRAPHS

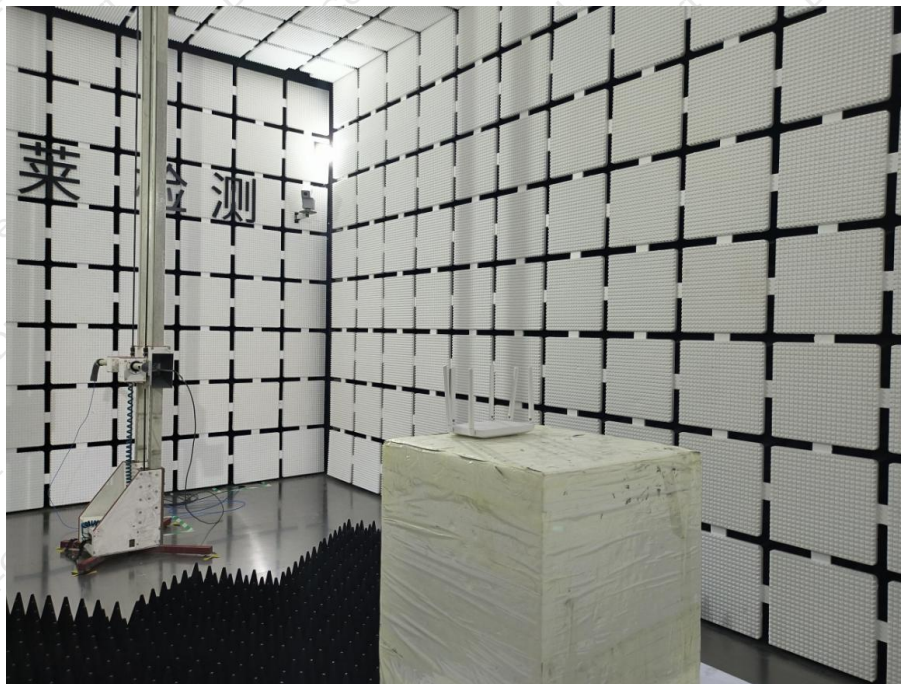



15. EUT PHOTOGRAPHS

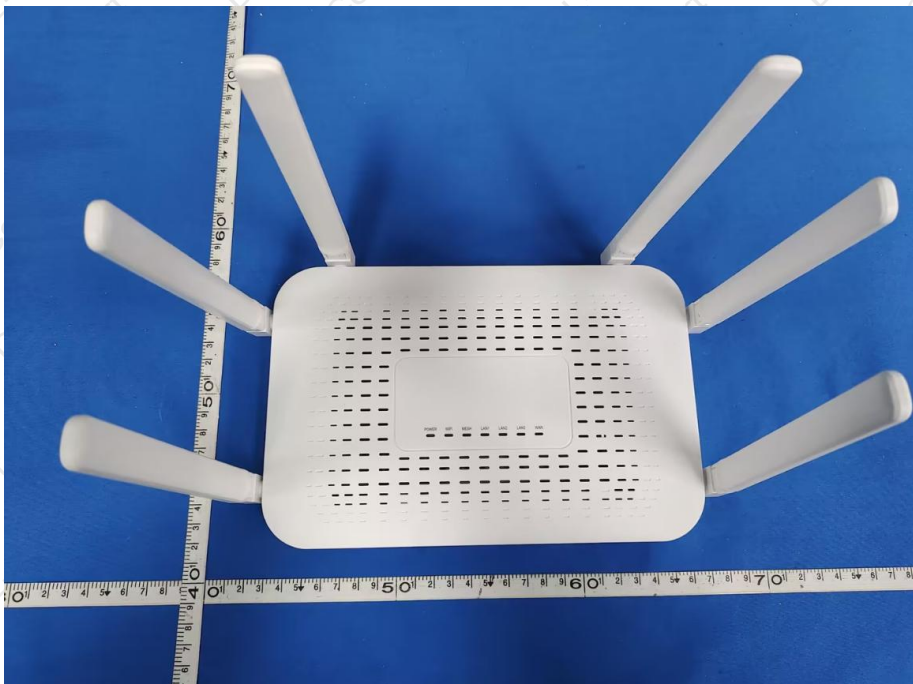
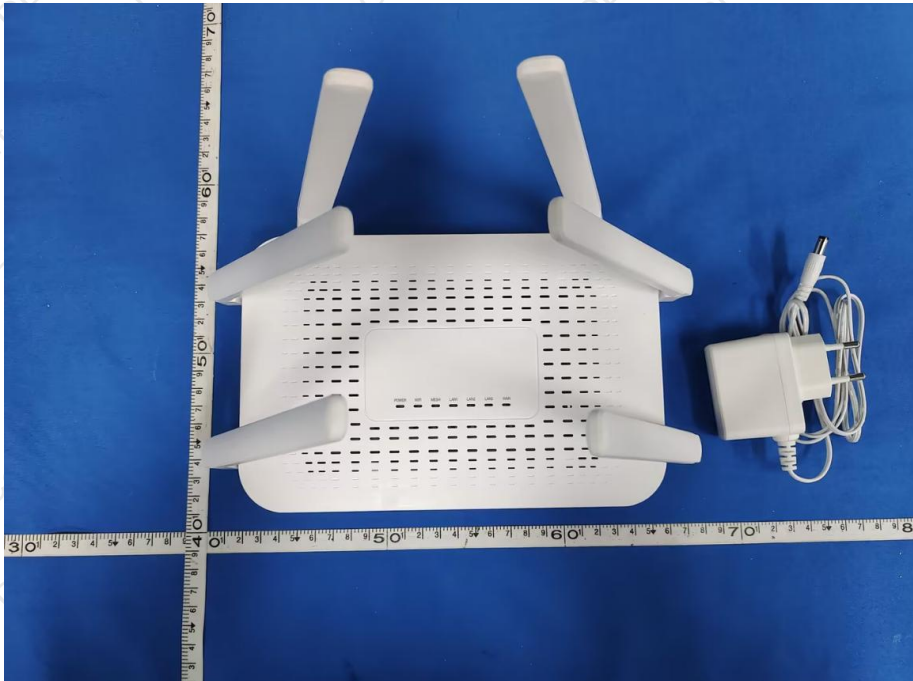



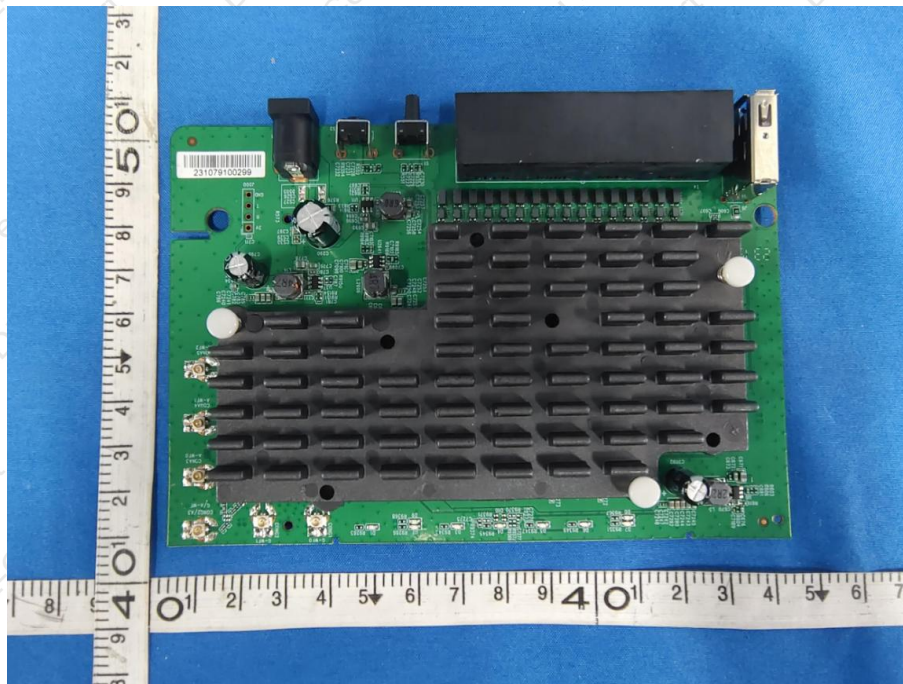

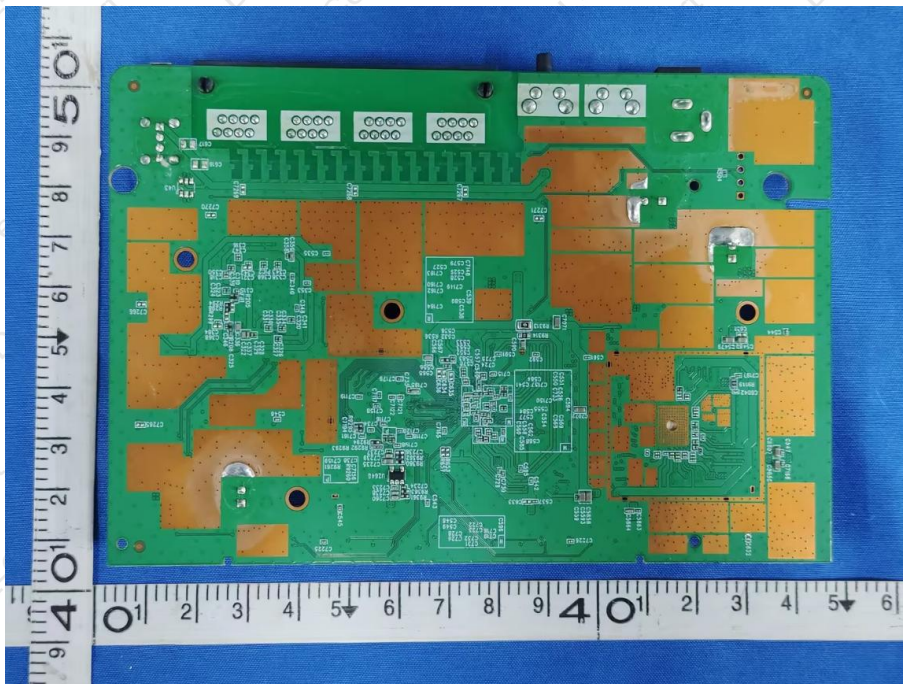
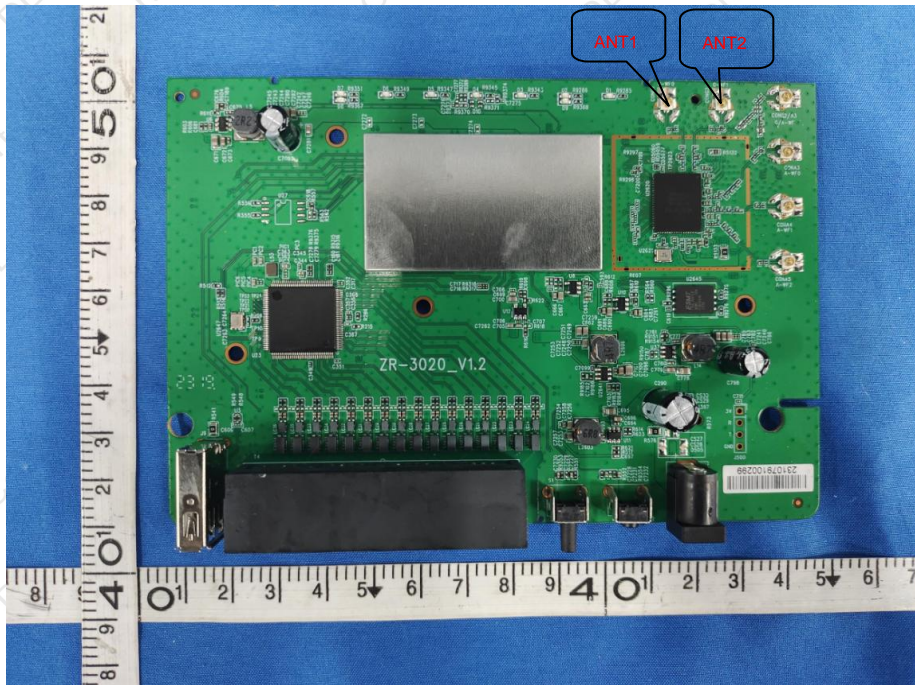



***** END OF REPORT *****